



STAEDTLER®

Head of ideas.

PROMOTIONAL PRODUCTS 2025

Discover the world of customisable STAEDTLER items

Découvrez le monde des produits STAEDTLER à personnaliser



IDEAS

FOR SCHOOL,
OFFICE+MORE

FOR ALL
AGES!

Personalized and
BRANDED.

Gifts
AND GIVE AWAYS



Head of ideas.

 Here at STAEDTLER, we believe in a world full of ideas – and bursting with amazing opportunities that are just waiting to be seized.

We believe that people are naturally creative, inquisitive and productive – and that they are always searching for new ways to rediscover their environment and release their own unique creativity. Because creativity makes people a little happier. And more relaxed.

For more than 185 years, we have been making it our mission to inspire people of all ages across the globe, helping them discover the joy of being creative. With our high-quality and innovative products, we seek to be a companion and source of inspiration for people of all ages who want to bring their own creative ideas to life. We do this out of a sense of tradition and a deep-seated commitment.

It started with a pencil: Today STAEDTLER is one of Germany's oldest industrial companies and ranks among the world's leading manufacturers and suppliers of writing, colouring, drawing and modelling products.

We have a long tradition of good ideas: Since that time Friedrich Staedtler invented the forerunner of today's pencil in the 17th century, we have consistently launched pioneering innovations.

Around 150 years later, more precisely in 1834, Johann Sebastian Staedtler succeeded in developing a coloured pencil with special features: it could be sharpened like a pencil, stuck to paper and shone with luminosity. His innovation made coloured painting and writing affordable and reached not only artist studios, but also nurseries and offices.

One of our most important principles is sustainable action - in terms of people and the environment. That is why we are always looking for new ways to use resources more efficiently, save energy and make our products even safer and long-lasting.

There is a brilliant idea behind every STAEDTLER product. Through our centuries-long experience and special advances in research and development, we have developed innovative products with the highest brand quality.

 Chez STAEDTLER, nous croyons en un monde plein d'idées – et débordant d'opportunités incroyables qui n'attendent qu'à être saisies.

Nous sommes convaincus que les gens sont naturellement créatifs, curieux et productifs et qu'ils sont toujours à la recherche de nouvelles façons de redécouvrir leur environnement et développer leur créativité. Parce que la créativité rend un peu plus heureux, et plus détendu.

Depuis plus de 185 ans, nous nous efforçons d'inspirer et d'aider les gens de tous âges à travers le monde, à prendre plaisir dans la créativité. Avec nos produits de haute qualité et innovants, nous cherchons à être un partenaire et une source d'inspiration pour tous ceux qui souhaitent donner vie à leurs propres idées créatives. Nous le faisons par tradition et par conviction profonde.

Tout a commencé avec un crayon : aujourd'hui, STAEDTLER est l'une des plus anciennes entreprises industrielles d'Allemagne et figure parmi les premiers fabricants mondiaux de produits d'écriture, de peinture, de dessin et de modélisation.

Tout a commencé avec un crayon : aujourd'hui, STAEDTLER est l'une des plus anciennes entreprises industrielles d'Allemagne et figure parmi les premiers fabricants mondiaux de produits d'écriture, de peinture, de dessin et de modélisation.

Environ 150 ans plus tard, plus précisément en 1834, Johann Sebastian Staedtler réussit à mettre au point un crayon de couleur aux propriétés particulières : il pouvait être taillé comme un crayon, tenait sur du papier et brillait à la lumière. Son innovation a rendu la peinture et l'écriture en couleur abordables et a atteint non seulement les ateliers d'artistes, mais également les chambres d'enfants et les bureaux.

L'un de nos principes fondamentaux est l'action durable, dans l'intérêt de l'homme et de l'environnement. C'est pourquoi nous recherchons constamment de nouveaux moyens d'utiliser plus efficacement les ressources, d'économiser l'énergie et de rendre nos produits encore plus sûrs et durables.

Chaque produit STAEDTLER cache une idée originale. A travers notre expérience séculaire et les progrès en recherche et développement, nous avons développé des produits de marque innovants de la plus haute qualité.

CONTENT

- 01 STAEDTLER PENCILS AND ACCESSORIES**
- 05 Graphite pencils made from home grown lime wood
 - 06 - 09 Graphite pencils
 - 10 - 11 Carpenter pencils, The Pencil, Noris® digital mini
 - 12 - 13 Erasers, Tailor-made packaging

- 02 STAEDTLER CREATIVE ASSORTMENT**
- 15 Coloured pencils
 - 16 ergosoft® coloured pencils, Rainbow pencil
 - 17 Colouring book sets
 - 18 - 19 triplus® color, Sidewalk chalks, Modelling clay
 - 20 - 21 Creative set, FIMO® kids modelling sets

- 03 STAEDTLER TEXTSURFER®**
- 23 Textsurfer® classic
 - 24 - 25 Textsurfer®, Desk stand, Textsurfer® dry

- 04 STAEDTLER LUMOCOLOR®**
- 27 Overview of main Lumocolor® applications
 - 28 - 29 Lumocolor® permanent special, permanent
 - 30 - 31 Lumocolor® non-permanent, permanent marker
 - 32 Lumocolor® permanent duo, flipchart marker
 - 33 Lumocolor® whiteboard marker
 - 34 - 35 Lumocolor® whiteboard pen, correctable, memo board

- 05 STAEDTLER TRIPLUS®**
- 37 Overview of triplus® sets
 - 38 - 39 triplus® mobile office, fineliner
 - 40 - 41 triplus® ball, micro, textsurfer®

- 06 STAEDTLER WRITING INSTRUMENTS**
- 43 Concrete Ballpoint pen
 - 44 TRX® Fountain pen, Rollerball pen
 - 45 TRX® Ballpoint pen, Mechanical pencil
 - 46 triplus® Fountain pen, Ballpoint pen
 - 47 Retractable ballpoint pen elance, Mechanical pencils
 - 48 - 49 Noris® writing pen, Pigment liner, Packaging, Gift boxes

- 07 STAEDTLER PREMIUM GIFTS**
- 51 Premium gifts "Children 2+"
 - 52 - 53 Premium gifts "Children / Students / Young people"

- 08 INFORMATION**
- 54 - 59 Advertising spaces

CONTENU

- CRAYONS GRAPHITE & ACCESSOIRES**
- Crayons graphite en bois de tilleul local
 - Crayons graphite
 - Crayons charpentier, The Pencil, Noris® digital mini
 - Gommes, Conditionnements

- ASSORTIMENT LOISIRS CRÉATIFS**
- Crayons de couleur
 - Crayons de couleur ergosoft®, Crayon « arc en ciel »
 - Sets de livres de coloriage
 - triplus® color, Craies pour trottoir, Pâte à modeler
 - Set créatif, Sets de modelage FIMO® kids

- TEXTSURFER®**
- Textsurfer® classic
 - Textsurfer®, Set de bureau, Textsurfer® dry

- LUMOCOLOR®**
- Vue d'ensemble des applications des Lumocolor®
 - Lumocolor® permanent special, permanent
 - Lumocolor® non-permanent, marqueur permanent
 - Lumocolor® permanent duo, flipchart marker
 - Lumocolor® whiteboard marker
 - Lumocolor® whiteboard pen, correctable, memo board

- TRIPLUS®**
- Vue d'ensemble des triplus® sets
 - triplus® mobile office, fineliner
 - triplus® ball, micro, textsurfer®

- INSTRUMENTS D'ÉCRITURE**
- Concrete Stylo-bille
 - TRX® Stylo-plume, Roller
 - TRX® Stylo-bille, Porte-mine
 - triplus® Stylo-plume, Stylo-bille
 - Stylo-bille rétractable elance, Porte-mines
 - Noris® writing pen, Pigment liner, Conditionnements, Boîtes cadeaux

- PRIMES**
- Primes « Enfants 2+ »
 - Primes « Enfants / Élèves / Jeunes »

- INFORMATIONS**
- Surfaces d'impression

Quality made in Germany

STAEDTLER's roots are in Nuremberg – still the headquarters of the STAEDTLER group. We proudly stand behind Germany as a business location and the tradition of the Nuremberg pencilmakers. Nearly two-thirds of all STAEDTLER products are manufactured in Germany.

Qualité « Made in Germany »

Les racines de STAEDTLER sont à Nuremberg, où se trouve toujours le siège social du groupe STAEDTLER. Nous soutenons le site économique allemand et la tradition de fabricants de crayons Nurembourgeois. Les deux tiers des produits manufacturés par STAEDTLER sont « Made in Germany ».



Look out for FSC™ certified products





Head of ideas.

Pencils and accessories

Crayons graphite & accessoires

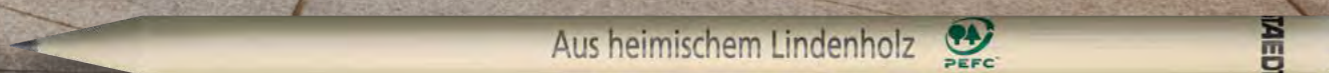
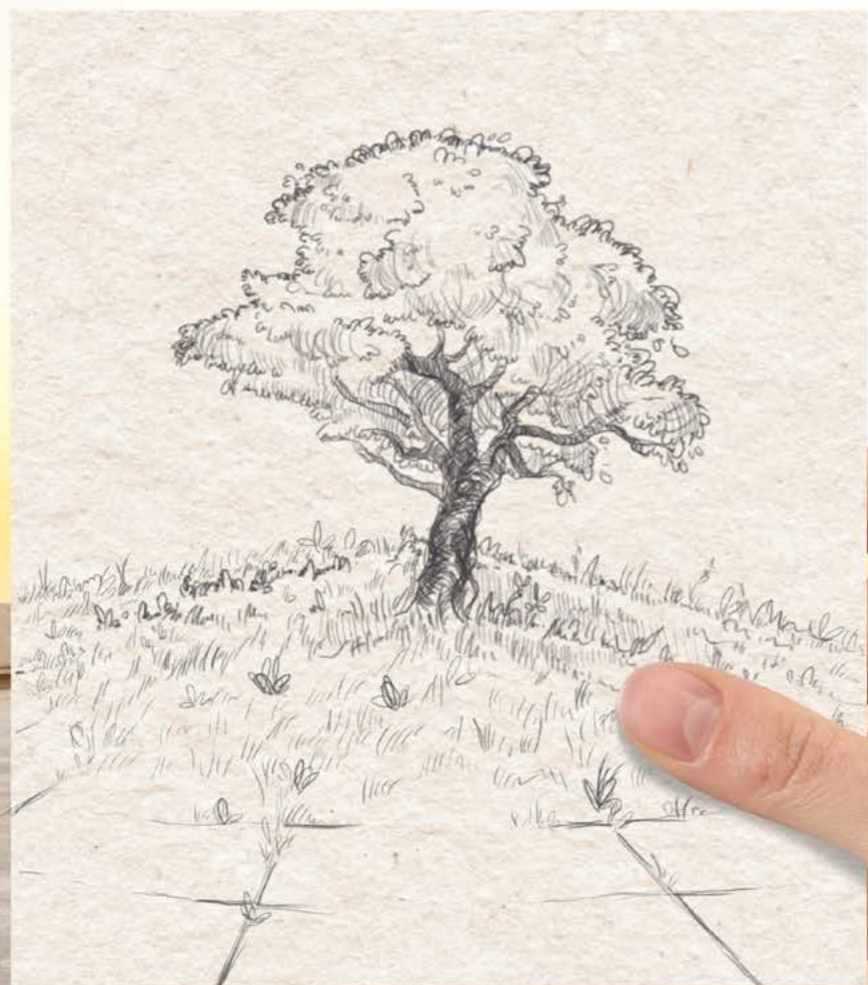

Graphite pencils made from home grown lime wood



161 30N W

- Graphite pencils of renowned STAEDTLER quality
- Untreated natural wood
- 175 mm length
- Minimum quantity: 2,000 pieces



Crayon graphite en bois de tilleul local

161 30N W

- Crayon graphite haute qualité STAEDTLER
- Bois naturel
- Longueur 175 mm
- Quantité minimum : 2.000 pièces



Silk-screen printing / Sérigraphie
 Stamping / Estampage
 Advertising space / Surface d'impression p. 54

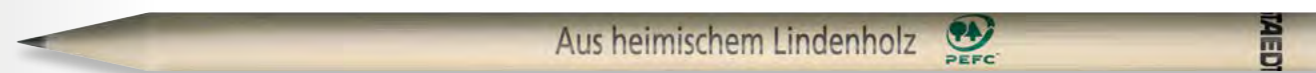

Insight into production process: From raw material until finished product – regionally produced and within short distances.



Aperçu dans le processus de production : De la matière première jusqu'à produit fini - produit local.



Lime wood

- Is the original kind of wood used within the pencil industry
- Has ideal sharpening properties
- Is used completely untreated
- Originates from certified and sustainable forests



Le bois

- Essence la plus utilisée dans l'industrie du crayon
- Propriétés de taillage idéales
- Utilisé complètement non traité
- Issu de forêts certifiées, gérées durablement

Home grown and processed

- Climate friendly: wood from short distances
- From home grown and sustainably operated forests
- Processed by local sawmills
- Manufactured and printed by STAEDTLER

Cultivé et transformé localement

- Climat adapté : bois de proximité
- Bois issu de forêts locales gérées durablement
- Transformé dans des scieries locales
- Fabriqué et marqué par STAEDTLER

Lime trees

- Grow in ecologically valuable mixed forests
- Stimulate soil fertility due to its very rapidly compostable greenery

L'arbre

- Cultivé dans des forêts écologiques mixtes
- Stimule la fertilité du sol grâce à ses propriétés compostables



Graphite pencils – round and hexagonal



Crayons graphite – ronds et hexagonaux



- Graphite pencils of renowned STAEDTLER quality
- Lacquered or natural wood
- With or without dipped end
- With or without eraser tip
- Ferrules available in silver, brass-coloured and black
- Eraser tips available in white, red and black

- Crayons graphite haute qualité STAEDTLER
- Vernis de couleur ou bois naturel
- Avec ou sans tête trempée
- Avec ou sans embout gomme
- Bague argentée, dorée ou noire au choix
- Gomme blanche, rouge ou noire au choix

Silk-screen printing (round pencils) / Sérigraphie (crayons ronds)

Stamping (round and hexagonal pencils) / Estampage (crayons ronds et hexagonaux)

Advertising space / Surface d'impression p. 54



Round / ronds



Eraser tips and ferrules / Gommets et bagues :



Standard lacquerings / Couleurs standards de vernis :

for round pencils / pour crayons ronds



for hexagonal pencils / pour crayons hexagonaux



Special lacquering colours upon request:

- from 10,000 pieces for pencils with 175 mm or 185 mm length
- from 20,000 pieces for pencils with 87 mm length

Couleurs spéciales de vernis sur demande :

- à partir de 10.000 pièces pour crayons avec longueur 175 mm ou 185 mm
- à partir de 20.000 pièces pour crayons avec longueur 87 mm



Hexagonal / hexagonaux

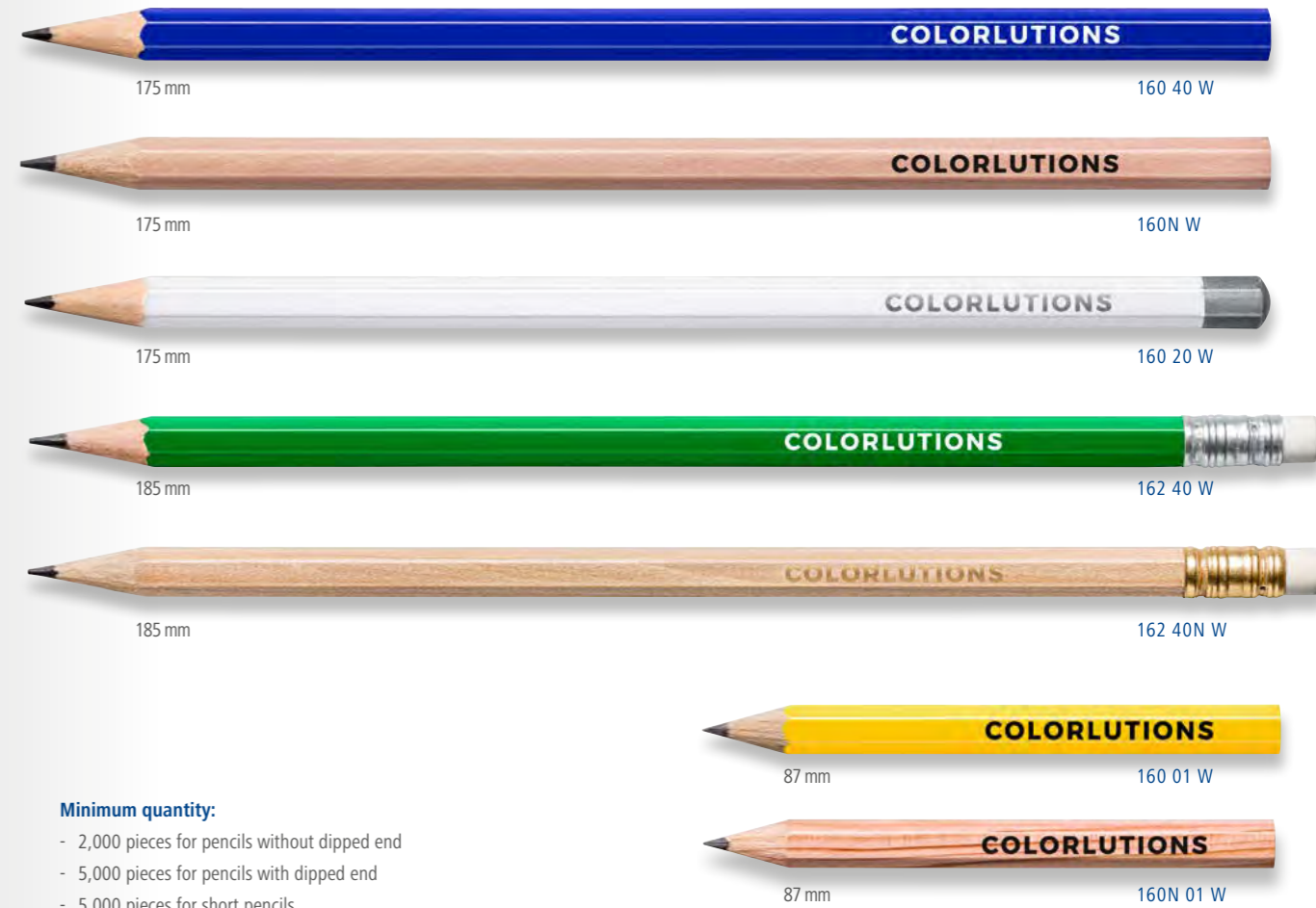

Minimum quantity:

- 2,000 pieces for pencils without dipped end
- 5,000 pieces for pencils with dipped end
- 5,000 pieces for short pencils

Quantité minimum :

- 2.000 pièces pour crayons sans tête trempée
- 5.000 pièces pour crayons avec tête trempée
- 5.000 pièces pour crayons courts



Graphite pencils in triangular shape

118 W / 118N W / 118 20 W

- Graphite pencils of renowned STAEDTLER quality
- Ergonomic triangular shape for relaxed and easy writing
- Lacquered or natural wood
- With or without dipped end
- 175 mm length
- Minimum quantity with cut end: 2,000 pieces
- Minimum quantity with dipped end: 5,000 pieces

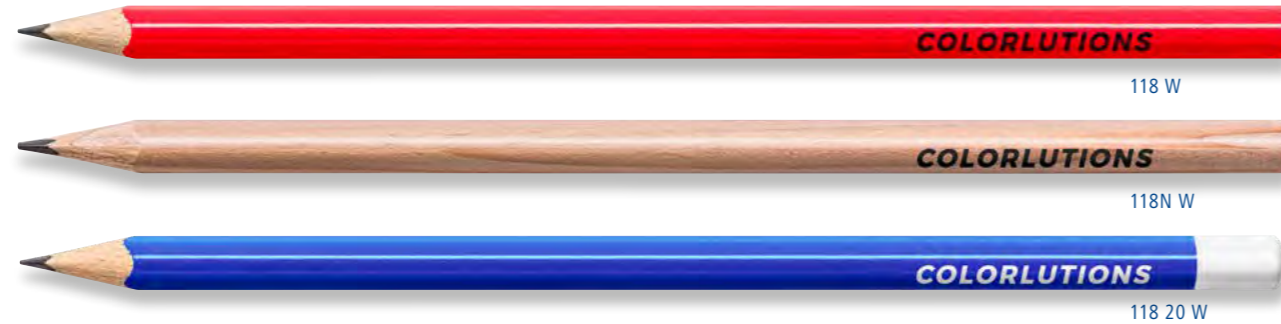

Standard lacquerings / Couleurs standards de vernis :



Stamping / Estampage
 Pad printing / Tampographie
 Advertising space / Surface d'impression p. 54



Crayons graphite triangulaires

118 W / 118N W / 118 20 W

- Crayon graphite haute qualité STAEDTLER
- Forme triangulaire ergonomique pour une écriture sans effort
- Vernis de couleur ou bois naturel
- Avec ou sans tête trempée
- Longueur 175 mm
- Quantité minimum sans tête trempée : 2.000 pièces
- Quantité minimum avec tête trempée : 5.000 pièces



Graphite pencils in triangular shape jumbo

119 W / 119N W

- Jumbo graphite pencil of renowned STAEDTLER quality
- Ergonomic triangular shape for relaxed and easy writing
- Lacquered (black, white) or natural wood
- Further lacquerings on request
- 175 mm length
- High break-resistance
- Minimum quantity: 2,000 pieces



Stamping / Estampage
 Pad printing / Tampographie
 Advertising space / Surface d'impression p. 54



Crayons graphite triangulaires jumbo

119 W / 119N W

- Crayon graphite haute qualité STAEDTLER gros module
- Forme triangulaire ergonomique pour une écriture sans effort
- Vernis de couleur (noir, blanc) ou bois naturel
- Autres couleurs de vernis sur demande
- Longueur 175 mm
- Haute résistance au bris
- Quantité minimum : 2.000 pièces



Black-dyed graphite pencils

165 10 W / 165 20 W

- Premium, black-dyed graphite pencils of renowned STAEDTLER quality
- Lacquered (black, white or silver)
- Further lacquerings on request
- With dipped end or eraser tip
- Ferrules available in silver, brass-coloured and black
- Eraser tips available in white, red and black
- 185 mm resp. 175 mm length
- Minimum quantity with eraser tip: 2,000 pieces
- Minimum quantity with dipped end: 5,000 pieces



Standard lacquerings / Couleurs standards de vernis :

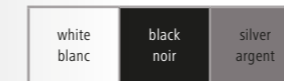

Silk-screen printing / Sérigraphie
 Stamping / Estampage
 Advertising space / Surface d'impression p. 54

Eraser tips and ferrules / Gommages et bagues :



Design graphite pencil

181 40 W

- Premium graphite pencil for design lovers
- Graphite pencil made from Upcycled Wood
- Characteristic design lines
- 175 mm length
- High break-resistance
- Minimum quantity: 1,000 pieces



Laser engraving / Gravure au laser
 Advertising space / Surface d'impression p. 54



Crayons graphite teintés noir dans la masse

165 10 W / 165 20 W

- Crayon graphite haut de gamme teinté noir dans la masse qualité STAEDTLER
- Vernis de couleur (noir, blanc ou argenté)
- Autres couleurs de vernis sur demande
- Avec tête trempée ou embout gomme
- Bague argentée, dorée ou noire au choix
- Gomme blanche, rouge ou noire au choix
- Longueur 185 mm ou 175 mm
- Quantité minimum avec embout gomme : 2.000 pièces
- Quantité minimum avec tête trempée : 5.000 pièces



Crayon graphite design

181 40 W

- Crayon graphite haut de gamme pour les amateurs de design
- Crayon graphite made from Upcycled Wood
- Design caractéristique
- Longueur 175 mm
- Haute résistance au bris
- Quantité minimum : 1.000 pièces



Carpenter pencils

168 15 W / 168 15N W

- Oval carpenter pencils of renowned STAEDTLER quality
- 240 mm length
- Lacquered (white or red) or natural wood
- Further lacquerings on request
- Digital imprint only possible on white lacquering
- Minimum quantity:
 - 1,000 pieces for pad printing or stamping
 - 500 pieces for digital imprint



168 15 W



168 15 W



168 15N W

- Stamping / Estampage
- Pad printing / Tampographie
- Digital imprint / Impression digitale
- Advertising space / Surface d'impression p. 55



The Pencil

9PTP581 W

- Graphite pencil made from Upcycled Wood
- With stylus pen tip from a new, conductive fabric
- Suitable for all devices with capacitive touch display (e.g. Apple iPad, iPhone, Samsung Galaxy, HTC, etc.)
- Single packaging
- Minimum quantity: 100 pieces

- Laser engraving / Gravure au laser
- Advertising space / Surface d'impression p. 55



Crayons charpentier

168 15 W / 168 15N W

- Crayon charpentier ovale de qualité STAEDTLER
- Longueur 240 mm
- Vernis de couleur (blanc ou rouge) ou bois naturel
- Autres couleurs de vernis sur demande
- Impression digitale seulement possible sur vernis blanc
- Quantité minimum :
 - 1.000 pièces pour tampographie ou estampage
 - 500 pièces pour impression digitale



The Pencil

9PTP581 W

- Crayon graphite made from Upcycled Wood
- Avec pointe stylet fabrique a partir d'un nouveau materiau conducteur
- Compatible avec tous les equipements a ecran tactile (ex : Apple iPad, iPhone, Samsung Galaxy, HTC, ...)
- Conditionnement à l'unité
- Quantité minimum : 100 pièces



The Pencil Set

9PTP581SEW

- Graphite pencil made from Upcycled Wood
- With stylus pen tip from a new, conductive fabric
- Suitable for all devices with capacitive touch display (e.g. Apple iPad, iPhone, Samsung Galaxy, HTC, etc.)
- With a protective cap with aluminium clip that acts as a pencil extender and also contains a sharpener and an eraser tip under the removable end
- Attractive cardboard box with 1 pencil and 1 extender
- Advertising space: Engraving on the pencil, pad printing or engraving on the extender
- Minimum quantity: 50 sets

- Pad printing / Tampographie
- Laser engraving / Gravure au laser
- Advertising space / Surface d'impression p. 55



Noris® digital mini

180M 22

- Cardboard box with 1 Noris digital mini pencil, replacement nib set and tool
- Compatible with end devices with electromagnetic resonance (EMR) technology
- No charging necessary
- Point: 0.7 mm
- With capacitive stylus tip as end cap for operating touchscreens
- Minimum quantity: 25 pieces

- Laser engraving / Gravure au laser
- Advertising space / Surface d'impression p. 55



Noris® digital mini

180M 22

- Étui carton avec 1 Noris digital mini crayon, un set de pointes de rechange y outil
- Compatible avec les terminaux dotés de la technologie EMR
- Pas de recharge nécessaire
- Pointe : 0,7 mm
- Avec pointe de stylet capacitif comme embout pour l'utilisation d'écrans tactiles
- Quantité minimum : 25 pièces





Erasers

526 201 W / 526 B30 W / 526 B40 W / 526 239 W

- Eraser of renowned STAEDTLER quality
- Consistent, optimal erasing performance
- Practically residue-free erasing
- Less crumbling
- Minimum quantity:
 - 1,000 pieces for digital imprint
 - 5,000 pieces for pad printing



Gommes

526 201 W / 526 B30 W / 526 B40 W / 526 239 W

- Gomme haute qualité STAEDTLER
- Qualité d'effaçage optimale
- Effaçage optimal régulier
- Peu de résidus
- Quantité minimum :
 - 1.000 pièces pour impression digitale
 - 5.000 pièces pour tampographie



- Digital imprint / Impression digitale
- Pad printing / Tampographie
- Advertising space / Surface d'impression p. 55

Available in 4 standardized sizes / 4 dimensions disponibles :

526 201 W: rectangular / rectangulaire, 48 x 33 x 9 mm



526 B30 W: rectangular / rectangulaire, 42 x 18 x 12 mm



526 B40 W: rectangular / rectangulaire, 32 x 15 x 12 mm



526 239 W: round / ronde, Ø 39 x 8 mm



Tailor-made packaging

- Upon request we are pleased to provide you with individual, tailor-made packaging solutions for our products, e.g. cardboard sleeves for pencils
- Quantities for tailor-made packaging are based on the minimum order quantities of the single products



Conditionnements

- Nous vous proposons sur demande des conditionnements pour nos produits, ex. étuis carton pour crayons graphite
- Le minimum de commande pour les étuis est fonction de la quantité minimum de commande de produits



- Pencil case made of grass paper
- Wood content can be significantly reduced through grass content
- Digital imprint possible



- Etui fabriqué en papier d'herbe
- La teneur en bois peut être considérablement réduite grâce à la teneur en herbe
- Impression digitale possible

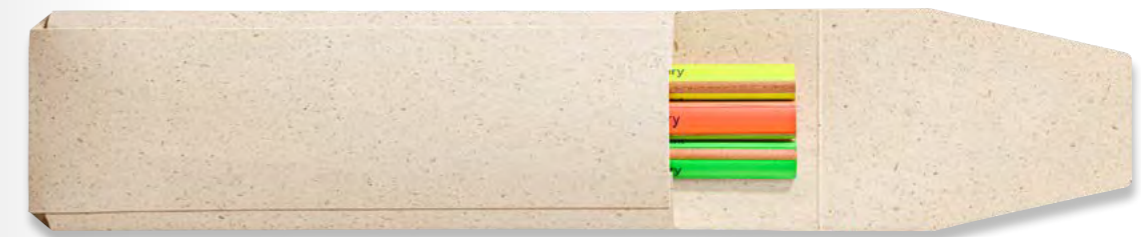

VGRASSTECK



V160 FS3SN

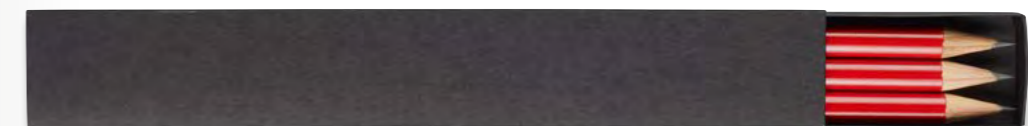

V160 FS3N



Head of ideas.

MADE FROM UPCYCLED WOOD



Upcycled Wood



Upcycled Wood stands for a responsible and sustainable dealing with the resource wood. We give wood residues from the wood industry a new, upgraded life as a high quality product.

By using the raw material wood effective, the process chain of „Made from Upcycled Wood“ products is much shorter than that of conventional wood-cased pencils. The lead and wood cladding are produced in a single operation using the co-extrusion process.

The wood used for upcycling comes from PEFC-certified forests that are managed in an environmentally, economically and socially sustainable manner.



Upcycled Wood est synonyme d'une utilisation responsable et durable de la matière première bois. Nous donnons à ces résidus de bois une nouvelle vie sous la forme d'un produit de qualité.

La chaîne de production des produits Made from Upcycled Wood est beaucoup plus courte que celle des crayons en bois traditionnels car le bois est utilisé beaucoup plus efficacement. Les mines et les revêtements en bois sont produits en une seule opération, selon le procédé de coextrusion.

Le bois utilisé pour l'upcyclage provient de forêts certifiées PEFC, qui sont gérées de manière durable sur le plan écologique, économique et social.



Coloured pencils



185 01C6DW, 18501C12DW, 185 C6D W, 185 C6DP W

- Cardboard box with 6 resp. 12 coloured pencils made from Upcycled Wood
- Ergonomic soft surface
- 87 mm resp. 175 mm length
- High break-resistance
- Coloured pencils always with STAEDTLER stamping
- Minimum quantity: 250 pieces



Crayons de couleur

185 01C6DW, 18501C12DW, 185 C6D W, 185 C6DP W

- Étui carton de 6 ou 12 crayons de couleur made from Upcycled Wood
- Surface douce ergonomique
- Longueur 87 mm ou 175 mm
- Haute résistance au bris
- Crayons de couleur toujours avec estampe STAEDTLER
- Quantité minimum : 250 pièces



Digital imprint / Impression digitale



Advertising space / Surface d'impression p. 55



185 01C6DW



18501C12DW



185 C6D W



185 C6DP W



ergosoft® coloured pencils

157 SB12 W



- 12 coloured pencils in practical stand-up STAEDTLER box
- Especially soft and richly coloured lead, Ø 3 mm
- Non-slip soft surface
- Ergonomic triangular shape for relaxed and easy drawing
- The white protective coating reinforces the lead and increases break resistance
- Coloured pencils always with STAEDTLER stamping
- Minimum quantity: 100 pieces



Crayons de couleur ergosoft®

157 SB12 W

- Étui chevalet STAEDTLER box de 12 crayons de couleur
- Mine extrêmement douce et de couleur intense, Ø 3 mm
- Surface douce antiglisse
- Forme triangulaire ergonomique pour une écriture sans effort
- Gaine de protection blanche anti-casse pour une mine plus solide
- Crayons de couleur toujours avec estampe STAEDTLER
- Quantité minimum : 100 pièces



Label / Étiquette

Label size / Dimension d'étiquette p. 59



Rainbow pencil

163 W / 163N W



- Coloured pencil with rainbow lead
- 3 colours in one pencil – blue, red, yellow
- 175 mm length
- Lacquered (white) or natural wood
- Further lacquerings on request
- Minimum quantity: 2,000 pieces



Crayon « arc en ciel »

163 W / 163N W

- Crayon de couleur à mine « arc en ciel »
- 3 couleurs en un seul crayon – bleu, rouge et jaune
- Longueur 175 mm
- Vernis de couleur (blanc) ou bois naturel
- Autres couleurs de vernis sur demande
- Quantité minimum : 2.000 pièces



163 W



163N W

Silk-screen printing / Sérigraphie

Stamping / Estampage

Advertising space / Surface d'impression p. 56



Colouring book sets

61 SETA5 W

- Two attractively designed colouring books, format A5
- 12 pages inside + 4 sides cover, paperback
- Cover: 300g/sqm recycled offset paper, inside: 100g/sqm recycled offset paper
- Alcohol free, carbon neutral and low-emission print
- Cover and inside pages can be personalised
- To be combined with digitally printed coloured pencil sets or other STAEDTLER branded products
- Minimum quantity: 100 pieces (standardized colouring book with customized boxes)



Sets de livres de coloriage

61 SETA5 W

- Deux livres de coloriage au design attractif, format A5
- 12 pages intérieures + 4 pages de couverture, broché
- Couverture : papier offset recycle 300g/m², pages intérieures : papier offset recycle 100g/m²
- Impression sans alcool, neutre en carbone et à faible émission
- La couverture et les pages intérieures peuvent être personnalisées
- Peut se combiner avec un set de crayons de couleur personnalisé par impression digitale ou tout autre produit de la marque STAEDTLER
- Quantité minimum : 100 pièces (livre de coloriage standard avec étui personnalisé)

Digital imprint (Coloured pencil sets) / Impression digitale (Sets de crayons de couleurs)

Label (Colouring books) / Étiquette (Livres de coloriage)



1

Colouring book,
12 pages

Livres de coloriage,
12 pages intérieures



2

Customized coloured pencil set with long or short coloured pencils

Set de crayons de couleur personnalisé avec crayons de couleur longs ou courts

► p. 15



triplus® color

323 W

- Fibre-tip pen with stable, pressure-resistant tip
- Ergonomic triangular barrel for relaxed and easy writing and colouring
- DRY SAFE – can be left uncapped for days without drying up
- Washes out of most textiles
- Line width approx. 1.0 mm
- 20 brilliant colours
- Housing made of 97% recycled plastic
- Also available in practical stand-up STAEDTLER box with either 4, 6 or 10 pens
- Minimum quantity: 500 pieces
250 sets



323 W



323 SB10 W

- Pad printing / Tampographie
- Label / Étiquette
- Advertising space / Surface d'impression p. 56, 59

Ink colours / Couleurs d'encre :



triplus® color

323 W

- Feutre de coloriage avec pointe bloquée, solide et résistante à la pression
- Corps triangulaire ergonomique pour une écriture sans effort
- DRY SAFE – permettant de laisser décapuchonné plusieurs jours sans sécher
- Lavable sur la plupart des textiles
- Largeur de trait env. 1,0 mm
- 20 couleurs brillantes
- Boitier fabriqué de 97% plastique recyclé
- Egalement disponible en étui chevalet STAEDTLER box de 4, 6 ou 10 feutres
- Quantité minimum : 500 pièces
250 sets



Sidewalk chalks

2365 W

- Cardboard box with 6 sidewalk chalks
- Colour assortment: white, yellow, orange, purple, blue and green
- Brilliant colours
- Washable
- Minimum quantity: 250 pieces

- Digital imprint / Impression digitale
- Advertising space / Surface d'impression p. 56



Craies pour trottoir

2365 W

- Étui carton de 6 craies pour trottoir
- Couleurs assorties : blanc, jaune, orange, violet, bleu et vert
- Couleurs brillantes
- Lavable
- Quantité minimum : 250 étuis



Modelling clay

842 C6 W

- Cardboard box with 6 bars of modelling clay
- Remains pliable and retains its shape
- Colours can be combined
- Ideal for school and kindergarten
- Filling selectable: standard, pastel or glitter colours
- Minimum quantity: 250 pieces



Pâte à modeler

842 C6 W

- Étui carton de 6 bâtons de pâte à modeler
- Reste toujours souple et conserve sa forme
- Couleurs peuvent être mélangées
- Idéal pour l'école et le jardin d'enfants
- Remplissage au choix : couleurs standards, pastel ou pailletées
- Quantité minimum : 250 pièces

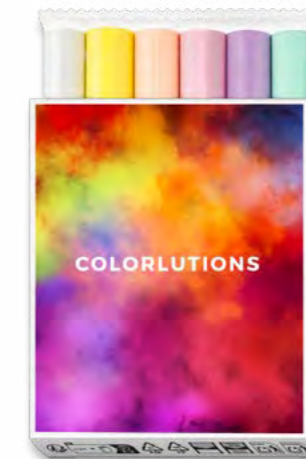
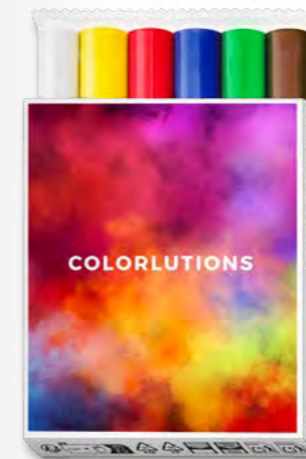

- Digital imprint / Impression digitale
- Advertising space / Surface d'impression p. 56





STAEDTLER® creative set

61 SB W

- Red or blue mini lunch box to be filled individually with:
 - 12-count coloured pencil set 185 01 C12
 - Metal sharpener 510 10
 - Modelling clay 842 C6
- Further fillings on request
- Minimum quantity: 100 pieces



Set creatif STAEDTLER®

61 SB W

- Mini boîte à repas rouge ou bleue composée de :
 - Étui de 12 crayons de couleur courts 185 01 C12
 - Taille-crayon métal 510 10
 - Pâte à modeler 842 C6
- Autres compositions sur demande
- Quantité minimum : 100 pièces

Label / Étiquette

Label size / Dimension d'étiquette p. 56

185 01 C12



842 C6



510 10



FIMO® kids modelling sets "form&play"

8034 W

- 12 different modelling sets with detailed step-by-step instruction, 4 FIMO kids blocks à 42 g (1.5 oz.) and modelling stick
- Decorative background scene printed on the inside of the box
- Oven-hardening modelling clay
- Super soft
- Sets with different levels of difficulty
- Minimum quantity: 50 sets

Label / Étiquette

Label size / Dimension d'étiquette p. 56



Sets de modelage FIMO® kids « form&play »

8034 W

- 12 différents sets de modelage avec instructions pas-à-pas détaillées, 4 blocs FIMO kids de 42 g et un ébauchoir
- Décor d'arrière-plan imprimé sur la boîte
- Pâte à modeler durcissant au four
- Particulièrement souple
- Sets avec différents niveaux de difficulté
- Quantité minimum : 50 sets



Set „Police race“



Set "Pets"



Set "Dino"



Set "Farm"



Set "Happy bees"



Set "Pony"



Set "Butterfly"



Set "Mermaid"



Set "Dreamy pets"



Set "Oceanlife"



Set "Cat"



Set "Unicorn"



Set "Police race"



HOUSING

97% RECYCLED PLASTIC

Textsurfer



Textsurfer® classic

364 RPP W

- Highlighter with large ink reservoir for extra-long highlighting performance
- Water-based ink
- INKJET SAFE – does not smudge inkjet printouts
- Fast-drying
- Housing made of 97% recycled plastic
- 4 neon colours
- Minimum quantity: 500 pieces





Textsurfer® classic

364 RPP W

- Surligneur avec un réservoir grande capacité pour une grande longueur d'écriture
- Encre à base d'eau
- INKJET SAFE – n'altère pas l'impression jet d'encre
- Séchage rapide
- Boitier fabriqué de 97% plastique recyclé
- 4 couleurs fluorescentes
- Quantité minimum : 500 pièces



 Silk-screen printing / Sérigraphie
 Pad printing / Tampographie
 Advertising space / Surface d'impression p. 56



Ink colours / Couleurs d'encre :





Textsurfer® classic

364 W / 364 C W

- Highlighter with large ink reservoir for extra-long highlighting performance
- Water-based ink
- Neon colours INKJET SAFE – does not smudge inkjet printouts
- Fast-drying
- 8 neon colours and 10 pastel and vintage colours
- Barrel opaque
- Minimum quantity: 500 pieces



Textsurfer® classic

364 W / 364 C W

- Surligneur avec un réservoir grande capacité pour une grande longueur d'écriture
- Encre à base d'eau
- Couleurs fluorescentes INKJET SAFE – n'altère pas l'impression jet d'encre
- Séchage rapide
- 8 couleurs fluorescentes et 10 couleurs pastel et vintage
- Corps opaque
- Quantité minimum : 500 pièces



- Silk-screen printing / Sérigraphie
- Pad printing / Tampographie
- Advertising space / Surface d'impression p. 56



Ink colours / Couleurs d'encre :



Barrel colours / Couleurs de corps :

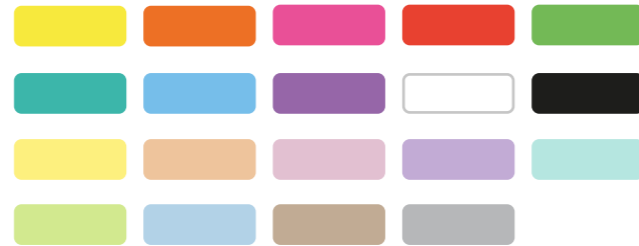

Any cap and barrel colours can be combined!

Combinaison possible des couleurs de capuchon et de corps !



Textsurfer® rainbow colours

364 R W

- Highlighter with large ink reservoir for extra-long highlighting performance
- Water-based ink
- INKJET SAFE – all colours do not smudge inkjet print-outs
- Fast-drying
- 8 neon colours
- Barrel transparent
- Minimum quantity: 500 pieces



Textsurfer® couleurs arc-en-ciel

364 R W

- Surligneur à grand réservoir d'encre pour une grande longueur de marquage
- Encre à base d'eau
- INKJET SAFE – n'altère pas l'impression jet d'encre
- Séchage rapide
- 8 couleurs fluorescentes
- Corps transparent
- Quantité minimum : 500 pièces



Ink colours / Couleurs d'encre :

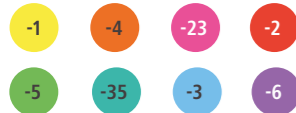

Barrel colours / Couleurs de corps :



- Silk-screen printing / Sérigraphie
- Pad printing / Tampographie
- Advertising space / Surface d'impression p. 56



Textsurfer® classic desk stand

364 S2 W

- Premium desk stand with 2 highlighters
- Any colours can be combined
- Packed in transparent box
- Minimum quantity: 250 pieces



Set de bureau Textsurfer® classic

364 S2 W

- Support argenté de 2 surligneurs
- Possibilité de combiner les couleurs
- Conditionnement individuel en boîte plastique transparente
- Quantité minimum : 250 pièces



- Pad printing / Tampographie
- Digital imprint / Impression digitale
- Advertising space / Surface d'impression p. 56



Textsurfer® dry

128 64 W

- Wood-cased highlighter pencil
- Ergonomic triangular shape
- Fluorescent, lightfast wax lead, Ø 4 mm
- No bleeding through thin paper, e.g. law texts, newspaper, bible passages
- No smudging of inkjet print-outs
- 5 neon colours
- Minimum quantity: 1,000 pieces



Textsurfer® dry

128 64 W

- Crayon surligneur à sec
- Forme triangulaire ergonomique
- Mine Ø 4 mm fluorescente et résistante à la lumière
- Ne traverse pas le papier fin (Code Civil, papier journal, Bible)
- N'altère pas l'impression jet d'encre
- 5 couleurs fluorescentes
- Quantité minimum : 1.000 pièces



- Stamping / Estampage
- Pad printing / Tampographie
- Advertising space / Surface d'impression p. 57

Neon colours / Couleurs fluorescentes :

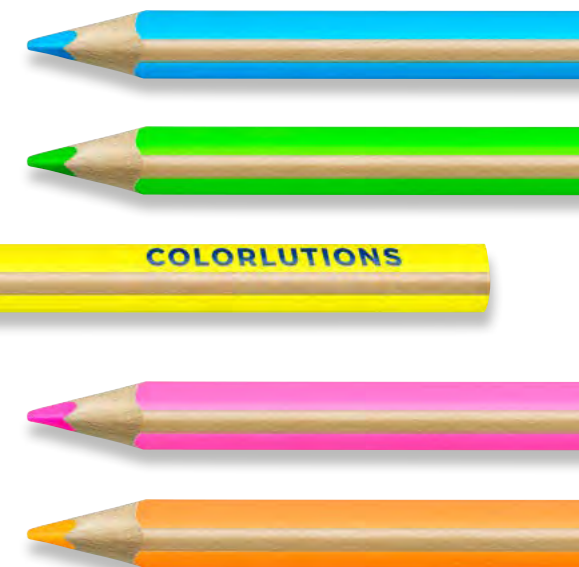



Head of ideas.

97%
RECYCLED
PLASTIC*

Permanently sustainable

*according to ISO 14021 (barrel, cap and end cap)



Overview of main Lumocolor® applications

Vue d'ensemble des applications des Lumocolor®

For detailed applications please see product description / Pour des applications détaillées consulter le descriptif produit

| | Permanent / Waterproof Permanent / Résistant à l'eau | | | | Non-permanent / Water-soluble Non-permanent / Soluble à l'eau | | | | |
|-------------------------------------------------------------------------------------------|---------------------------------------------------------|--------------|--------------|--------------|------------------------------------------------------------------|-----------|-----------|-------------|--------------|
| | 313 / 314 / 317 / 318 | 319 | 348 | 350 / 352 | 311 / 312 / 315 / 316 | 305 | 301 | 351 / 351 B | 356 / 356 B |
| For writing on / Pour écrire sur : | | | | | | | | | |
| Paper / Papier | - p. 29 - | - p. 28 - | - p. 32 - | - p. 31 - | - p. 30 - | - p. 35 - | - p. 34 - | - p. 33 - | - p. 32 - |
| Cardboard / Carton | ✓ | | ✓ | ✓ | ✓ | ✓ | | | ✓ |
| Film (overhead, e.g.) / Film (rétroprojection) | ✓ | ✓ | ✓ | ✓ | ✓ | ✓ | | | |
| Plastic / Plastique | ✓ | ✓ | ✓ | ✓ | ✓ | ✓ | | | |
| Metal / Métal | ✓ | ✓ | ✓ | ✓ | ✓ | | | | |
| Whiteboards / Tableaux blancs | | | | | | ✓ | ✓ | ✓ | |
| Polystyrene / Styrofoam / Polystyrène | ✓ | | ✓ | ✓ | ✓ | | | | |
| Glass, Porcelain / Verre, Porcelaine | ✓ | ✓ | ✓ | ✓ | ✓ | ✓ | ✓ | ✓ | |
| Wood, Stone / Bois, Pierre | ✓ | | ✓ | ✓ | | | | | |
| CDs, DVDs, BDs / CD, DVD | ✓ | | | | | | | | |
| Coated surfaces / Surfaces traitées | | ✓ | | | | | | | |
| Textiles / Tissus | | | | | | | | | |
| Ink, lead characteristics / Caractéristiques des encres et pointes : | | | | | | | | | |
| Fast-drying / Séchage rapide ⁽¹⁾ | ✓ | ✓ | ✓ | ✓ | ✓ | | ✓ | ✓ | ✓ |
| DRY SAFE | ✓ | | ✓ | ✓ | | | | ✓ | ✓ |
| Highly lightfast / Résistant à la lumière | black / noir | black / noir | black / noir | black / noir | black / noir | ✓ | ✓ | ✓ | black / noir |
| Weatherproof / Résistant aux intempéries | | | | black / noir | | | | | |
| Smudge-proof / Ne bave pas ⁽¹⁾ | ✓ | ✓ | ✓ | ✓ | ✓ | ✓ | | | |
| Dry correcting ⁽¹⁾ , Dry wipe / Marquage à sec ⁽¹⁾ , Effaçage à sec | | | | | | ✓ | ✓ | ✓ | |
| No bleeding through paper / Ne traverse pas le papier | | | | | | ✓ | | | ✓ |
| Range / Gamme : | | | | | | | | | |
| Number of colours / Nombre de couleurs | 8 | 2 | 4 | 8 | 8 | 4 | 4 | 6 | 6 |
| Refillable / Rechargeable | ✓ | | ✓ | ✓ | ✓ | ✓ | | ✓ | ✓ |

⁽¹⁾ On non-absorbent surfaces / Sur surfaces lisses



Lumocolor® permanent special

319 W

- For many special applications such as coated surfaces, nano coatings, optical glass, laboratory glass
- Adheres to many special surfaces which other fine markers do not adhere to
- The black Lumocolor permanent special F and M can also be used for textiles and wide variety of outdoor applications
- Excellent smudge-proof and waterproof qualities on almost all surfaces
- 3 line widths, 2 ink colours (Red only available in F)
- Housing made of 97% recycled plastic
- Minimum quantity: 500 pieces



Lumocolor® permanent special

319 W

- Pour de multiples applications comme les surfaces enduites, l'enduction nanotechnologie, les verres optiques, les verres de laboratoire
- Adhère sur les surfaces sur lesquelles l'encre d'autres n'adhèrent pas
- Les feutres Lumocolor permanent special noir pointe F et M peut également être utilisé sur les textiles et la plupart des utilisations en extérieur
- Excellente résistance à l'eau et aux frottements sur la plupart des surfaces
- 3 largeurs de trait, 2 couleurs d'encre (Rouge uniquement disponible en F)
- Boitier fabriqué de 97% plastique recyclé
- Quantité minimum : 500 pièces



Silk-screen printing / Sérigraphie
 Advertising space / Surface d'impression p. 57



| | | | | | |
|--|------------------------------------------------------------------|------------------------------------------------------------|--|-----------------------------------------------------------------------------------------------------|-------------------------------------------------------------------------------------------------------------|
| | Waterproof | Résistant à l'eau | | Airplane-safe Automatic pressure equalization prevents pen from leaking on board aircraft | Sécurité avion L'équilibrage automatique de la pression empêche le stylo de fuir |
| | Weatherproof | Résistant aux intempéries | | Lightfast High level of lightfastness: Writing is still clearly legible years later! | Résistant aux U.V. Haut degré de résistance à la lumière. Toujours lisible des années plus tard ! |
| | Dries in seconds Therefore ideal for left-handed users | Sec en quelques secondes Idéal pour les gauchers | | Universal pen / marker For labelling and marking of just about every material | Feutres et marqueurs universels Pour le marquage et l'étiquetage de presque toutes surfaces |

Ink colours / Couleurs d'encre :

- 9
- 9 -2
- 9

Line width / Largeur de trait :

| | | |
|----------|--|------------------------------|
| S | | approx. / env. 0,4 mm |
| F | | approx. / env. 0,6 mm |
| M | | approx. / env. 1,0 mm |



Lumocolor® permanent

313 W / 314 W / 317 W / 318 W

- Universal pen for overhead projection and almost all surfaces; S and M also suitable for use on CDs/DVDs
- DRY SAFE – can be left uncapped for days without drying up
- Excellent smudge-proof and waterproof qualities on almost all surfaces
- 4 line widths, 8 colours
- Housing made of 97% recycled plastic
- Also available in practical stand-up STAEDTLER box
- Minimum quantity: 500 pieces
500 sets



Lumocolor® permanent

313 W / 314 W / 317 W / 318 W

- Feutre universel pour la rétroprojection et la plupart des surfaces; pointes S et M aussi pour les CD / DVD
- DRY SAFE – permettant de laisser décapuchonné plusieurs jours sans sécher
- Excellente résistance à l'eau et aux frottements sur la plupart des surfaces
- 4 largeurs de trait, 8 couleurs
- Boitier fabriqué de 97% plastique recyclé
- Egalement disponible en étui chevalet STAEDTLER box
- Quantité minimum : 500 pièces
500 sets



Silk-screen printing / Sérigraphie
 Label / Étiquette
 Advertising space / Surface d'impression p. 57, 59



313 W



313 WP4 W

Ink colours / Couleurs d'encre :

- 1
- 2
- 3
- 4
- 5
- 6
- 7
- 9

Line width / Largeur de trait :

| | | | |
|-------|----------|--|---------------------------------------------|
| 313 W | S | | approx. / env. 0,4 mm |
| 318 W | F | | approx. / env. 0,6 mm |
| 317 W | M | | approx. / env. 1,0 mm |
| 314 W | B | | approx. / env. 1,0 mm or / ou 2,5 mm |



Lumicolor® non-permanent

311 W / 312 W / 315 W / 316 W

- Universal pen for overhead projection and almost all surfaces
- Water-soluble ink
- 4 line widths, 8 colours
- Housing made of 97% recycled plastic
- Also available in practical stand-up STAEDTLER box
- Minimum quantity: 500 pieces
500 sets



Lumicolor® non-permanent

311 W / 312 W / 315 W / 316 W

- Feutre universel pour la rétroprojection et la plupart des surfaces
- Encre soluble à l'eau
- 4 largeurs de trait, 8 couleurs
- Boîtier fabriqué de 97% plastique recyclé
- Egalement disponible en étui chevalet STAEDTLER box
- Quantité minimum : 500 pièces
500 sets



- Silk-screen printing / Sérigraphie
- Label / Étiquette
- Advertising space / Surface d'impression p. 57, 59



311 W



311 WP4 W

Ink colours /
Couleurs d'encre :



Line width /
Largeur de trait :

- | | | | |
|-------|----------|--|--------------------------------------------|
| 311 W | S | | approx. / env. 0,4 mm |
| 316 W | F | | approx. / env. 0,6 mm |
| 315 W | M | | approx. / env. 1,0 mm |
| 312 W | B | | approx. / env. 1,0 mm or / ou 2,5 mm |



Lumicolor® permanent marker

350 W / 352 W

- Excellent smudge-proof and waterproof qualities on almost all surfaces
- DRY SAFE – can be left uncapped for days without drying up
- 2 line widths, 8 colours
- Lightfast
- Also available in practical stand-up STAEDTLER box
- Minimum quantity: 500 pieces
500 sets



Lumicolor® marqueur permanent

350 W / 352 W

- Excellente résistance à l'eau et aux frottements sur la plupart des surfaces
- DRY SAFE – permettant de laisser décapuchonné plusieurs jours sans sécher
- 2 largeurs de trait, 8 couleurs
- Résistant à la lumière
- Egalement disponible en étui chevalet STAEDTLER box
- Quantité minimum : 500 pièces
500 sets



350 WP4 W

Ink colours /
Couleurs d'encre :



352 W



350 W

- Silk-screen printing / Sérigraphie
- Label / Étiquette
- Advertising space / Surface d'impression p. 57, 59

Line width /
Largeur de trait :

- | | |
|--|--------------------------|
| | approx. / env. 2 mm |
| | approx. / env. 2-5 mm |



Lumocolor® permanent duo

348 W

- Handy-sized marker with two tips for writing and marking on almost all surfaces
- Excellent smudge-proof and waterproof qualities
- Black is lightfast
- DRY SAFE – can be left uncapped for days without drying up
- Line widths F (approx. 0.6 mm) and M (approx. 1.5 mm), 4 colours
- Minimum quantity: 1,000 pieces

Silk-screen printing / Sérigraphie
 Advertising space / Surface d'impression p. 57

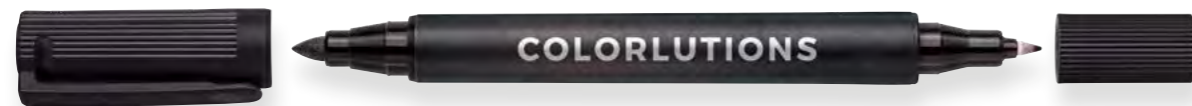

Ink colours / Couleurs d'encre :



Lumocolor® flipchart marker

356 W / 356 B W

- Ideal for use on paper as ink does not bleed through
- Dries in seconds, therefore ideal for left-handed users
- DRY SAFE – can be left uncapped for days without drying up
- 2 line widths, 6 colours
- Housing made of 97% recycled plastic
- Minimum quantity: 500 pieces



Silk-screen printing / Sérigraphie
 Advertising space / Surface d'impression p. 57

Ink colours / Couleurs d'encre :



Line width / Largeur de trait :



Lumocolor® permanent duo

348 W

- Marqueur compact double pointe pour écrire et marquer sur la plupart des surfaces
- Excellente résistance à l'eau et aux frottements
- L'encre noire est résistante à la lumière
- DRY SAFE – permettant de laisser décapuchonné plusieurs jours sans sécher
- Largeur de trait F (env. 0,6 mm) et M (env. 1,5 mm), 4 couleurs
- Quantité minimum : 1.000 pièces



Lumocolor® whiteboard marker

351 W / 351 B W

- Can be dry-wiped from whiteboards and surfaces like glass and porcelain without leaving a trace
- DRY SAFE – can be left uncapped for days without drying up
- 2 line widths, 6 colours
- Housing made of 97% recycled plastic
- Also available in practical stand-up STAEDTLER box
- Minimum quantity: 500 pieces / 500 sets

Silk-screen printing / Sérigraphie
 Label / Étiquette
 Advertising space / Surface d'impression p. 57, 59



Lumocolor® whiteboard marker

351 W / 351 B W

- Effaçable à sec sur tableaux blancs et surfaces telles que le verre et la porcelaine sans laisser de traces
- DRY SAFE – permettant de laisser décapuchonné plusieurs jours sans sécher
- 2 pointes, 6 couleurs
- Boîtier fabriqué de 97% plastique recyclé
- Egalement disponible en étui chevalet STAEDTLER box
- Quantité minimum : 500 pièces / 500 set



351 WP4 W



351 W



351 B W

Ink colours / Couleurs d'encre :



Line width / Largeur de trait :





Lumicolor® whiteboard pen

301 W

- Whiteboard marker in pen format
- Can be dry-wiped without residue from whiteboards and smooth surfaces like glass and porcelain
- Line width M, 4 colours
- Housing made of 97% recycled plastic
- Also available in practical stand-up STAEDTLER box
- Minimum quantity: 500 pieces
500 sets



Lumicolor® whiteboard pen

301 W

- Marqueur pour tableaux blancs au format d'un feutre
- Effaçable à sec sur tableaux blancs et surfaces telles que le verre et la porcelaine sans laisser de traces
- Largeur de trait M, 4 couleurs
- Boitier fabriqué de 97% plastique recyclé
- Egalement disponible en étui chevalet STAEDTLER box
- Quantité minimum : 500 pièces
500 sets



- Silk-screen printing / Sérigraphie
- Label / Étiquette
- Advertising space / Surface d'impression p. 57, 59

Ink colours /
Couleurs d'encre :



Line width /
Largeur de trait :
M approx. / env.
1,0 mm



301 W



301 WP4 W



Lumicolor® correctable

305 W

- For write-on films and other film surfaces such as sheet covers, laminates and school whiteboards
- Can be dry-wiped from many smooth surfaces
- Does not bleed through paper
- Wiper integrated in end plug; cap with roll stop
- 2 line widths, 4 colours
- Also available in practical stand-up STAEDTLER box
- Minimum quantity: 500 pieces
500 sets



Lumicolor® correctable

305 W

- Pour l'écriture et le marquage sur films transparents, ardoises blanches et toutes surfaces lisses (pochettes transparentes ou de lamination)
- Effaçable à sec sur surfaces lisses
- Ne traverse pas le papier
- Effacette intégrée dans l'embout du feutre; capuchon équipé d'un système anti-roulis
- 2 largeurs de trait, 4 couleurs
- Egalement disponible en étui chevalet STAEDTLER box
- Quantité minimum : 500 pièces
500 sets



305 W

- Silk-screen printing / Sérigraphie
- Label / Étiquette
- Advertising space / Surface d'impression p. 57, 59

Ink colours /
Couleurs d'encre :



Line width /
Largeur de trait :

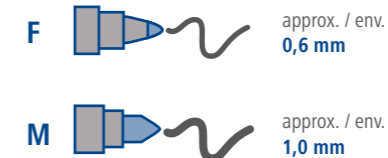

305 WP4 W



Lumicolor® memo board

641 MB W

- Rewriteable and self-adhesive notice board
- Includes 1 STAEDTLER Lumicolor correctable (black) and self-adhesive pen clip (white)
- Easy removable
- A5 format
- Can be dry-wiped, enabling flexible scheduling
- Individual digital logo imprint, advertising space: 12 x 4 cm
- Packed in poly-bag
- Minimum quantity: 100 pieces



Lumicolor® memo board

641 MB W

- Mémo board réutilisable et auto-adhésif
- Livré avec un STAEDTLER Lumicolor correctable (noir) et un porte-stylo adhésif (blanc)
- Repositionnable
- Format A5
- Effaçable à sec, permettant une utilisation flexible
- Marquage d'un logo par impression digitale, surface d'impression : 12 x 4 cm
- Conditionné en polybag
- Quantité minimum : 100 pièces



Digital imprint / Impression digitale





Head of ideas.

triplus



triplus® Sets

Create your own set!

1 Choose a box / Choisissez votre étui :

transparent / translucide or / ou black / noir

2 All products from the triplus product range can be combined in this set:
Tous les instruments de la gamme triplus peuvent être combinés dans ce set :

| | | |
|---------------------------------------------------------------------------------------------------------------------------------------------------------------------------------------------|-----------------------------------------------------------------------------------------------------------------------------------------------------------------|-----------------------------------------------------------------------------------------------------------------------------------------------------------------------|
| triplus® fineliner Fibre-tip pen in 4 different colours, with a super-fine tip, line width approx. 0.3 mm / Feutre d'écriture en 20 couleurs, pointe superfine 0,3 mm – p. 39 | triplus® micro Mechanical pencil with two optional line widths 0.5 mm and 0.7 mm / Porte-mine en 2 diamètres disponibles 0,5 mm et 0,7 mm – p. 40 | triplus® color Fibre-tip pen in 20 different colours, line width approx. 1.0 mm / Feutre de coloriage en 20 couleurs, largeur de trait ≈ 1,0 mm – p. 18 |
| triplus® ball Ballpoint pen in 4 different colours, line width M / Stylo-bille en 4 couleurs, largeur de trait M – p. 40 | triplus® textsurfer® Highlighter in 14 colours, with a variable width of 1-4 mm / Sur-ligneur en 14 couleurs, pointe 1 à 4 mm – p. 41 | |

3 Optional with ruler for filing in ring binders:
En option avec règle perforée pour rangement dans un classeur :



triplus® mobile office

34 SB4 W / 34 SB4R W

- The mini office for people on the go
- With this assortment in the stand-up STAEDTLER box, you will always have the right writing instrument at hand anytime and anywhere
- Optional: with ruler for filing in ring binders
- Minimum quantity: 250 pieces

Pad printing / Tampographie
 Label / Étiquette
 Advertising space / Surface d'impression p. 58, 59



34 SB4R W

34 SB4 W

The practical STAEDTLER triplus® mobile office contains /
 L'étui STAEDTLER triplus® mobile office comprend :

| | | | | | | | |
|--|-----------------------------------------------------------------------------------------|--|----------------------------------------------------------------------------------|--|---------------------------------------------------------------------------------------------|--|-----------------------------------------------------------------------------------------------------------------|
| | triplus® fineliner, ink: black triplus® fineliner, encre : noire | | triplus® ball, ink: blue M triplus® ball, encre : bleue M | | triplus® micro, line width: 0.5 mm triplus® micro, diamètre : 0,5 mm | | triplus® textsurfer, ink: neon yellow triplus® textsurfer, encre : jaune fluorescent |
|--|-----------------------------------------------------------------------------------------|--|----------------------------------------------------------------------------------|--|---------------------------------------------------------------------------------------------|--|-----------------------------------------------------------------------------------------------------------------|



triplus® mobile office

34 SB4 W / 34 SB4R W

- Le bureau nomade pour les itinérants
- Étui chevalet STAEDTLER box de 4 stylos pour disposer d'un nécessaire d'écriture idéal à tout moment
- En option : avec règle perforée pour rangement dans un classeur
- Quantité minimum : 250 pièces



triplus® fineliner

334 W

- Fibre-tip pen with superfine, metal-clad tip
- Ergonomic triangular barrel for effortless writing and colouring
- DRY SAFE – can be left uncapped for days without drying up
- Washes out of many textiles
- Line width approx. 0.3 mm
- 4 brilliant colours
- Housing made of 97% recycled plastic
- Also available in practical stand-up STAEDTLER box
- Minimum quantity: 500 pieces
250 sets

Pad printing / Tampographie
 Label / Étiquette
 Advertising space / Surface d'impression p. 58, 59



334 SB4 W

334 W

Line width /
Largeur de trait :



Ink colours /
Couleurs d'encre :



i Further ink colours available
as of 5,000 pcs
Autres couleurs d'encre disponible
à partir de 5.000 pièces



triplus® fineliner

334 W

- Feutre d'écriture pointe superfine baguée métal
- Corps triangulaire ergonomique pour une écriture sans effort
- DRY SAFE – permettant de laisser décapuchonné plusieurs jours sans sécher
- Lavable sur la plupart des textiles
- Largeur de trait env. 0,3 mm
- 4 couleurs brillantes
- Boitier fabriqué de 97% plastique recyclé
- Egalement disponible en étui chevalet STAEDTLER box
- Quantité minimum : 500 pièces
250 sets



triplus® ball

437 W

- Ballpoint pen with a particularly smooth writing performance
- Ergonomic triangular barrel for relaxed and easy writing
- Line width M
- 4 brilliant colours
- Also available in practical stand-up STAEDTLER box
- Minimum quantity: 500 pieces
250 sets



437 W



triplus® ball

437 W

- Stylo-bille avec une écriture particulièrement douce
- Corps triangulaire ergonomique pour une écriture sans effort
- Largeur de trait M
- 4 couleurs brillantes
- Egalement disponible en étui chevalet STAEDTLER box
- Quantité minimum : 500 pièces
250 sets



- Pad printing / Tampographie
- Label / Étiquette
- Advertising space / Surface d'impression p. 58, 59

Line width /
Largeur de trait :



437 SB4 W

Ink colours /
Couleurs d'encre :



triplus® micro

774 W

- Mechanical pencil for writing
- Ergonomic triangular barrel for relaxed and easy writing
- Extra-long twist eraser
- Line width: 0.5 mm or 0.7 mm
- Always with STAEDTLER imprint and line width indication
- Minimum quantity: 250 pieces

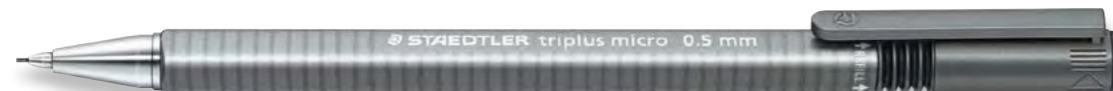

triplus® micro

774 W

- Porte-mine pour l'écriture
- Corps triangulaire ergonomique pour une écriture sans effort
- Gomme extra longue extractible par rotation
- Largeur de trait : 0,5 mm ou 0,7 mm
- Toujours avec marquage standard STAEDTLER et indication du diamètre de la mine
- Quantité minimum : 250 pièces

- Pad printing / Tampographie
- Advertising space / Surface d'impression p. 58



triplus® textsurfer®

362 W

- Highlighter with pleasantly soft, variable tip for very fine to broad highlighting
- Ergonomic triangular barrel
- INKJET SAFE – does not smudge inkjet printouts
- Variable line width from approx. 1–4 mm
- 4 neon colours
- Also available in practical stand-up STAEDTLER box
- Minimum quantity: 500 pieces
250 sets



362 W

- Pad printing / Tampographie
- Label / Étiquette
- Advertising space / Surface d'impression p. 58, 59

Ink colours neon /
Couleurs fluorescentes :



362 SB4 W



triplus® textsurfer® - pastel & vintage

362 C W

- Highlighter with pleasantly soft, variable tip for very fine to broad highlighting
- Ergonomic triangular barrel
- Variable line width from approx. 1–4 mm
- 10 pastel and vintage colours
- Also available in practical stand-up STAEDTLER box
- Minimum quantity: 500 pieces



- Pad printing / Tampographie
- Advertising space / Surface d'impression p. 58

Ink colours /
Couleurs d'encre :



triplus® textsurfer® - pastel & vintage

362 C W

- Surligneur à pointe ogive douce permettant de surligner d'un trait fin ou large
- Corps triangulaire ergonomique
- Largeur de trait variable de 1 à 4 mm
- 10 couleurs pastel et vintage
- Egalement disponible en étui chevalet STAEDTLER box
- Quantité minimum : 500 pièces





Head of ideas.



PURE BETON
CONCRETE
Handcrafted



Concrete Ballpoint pen

441CON W

- Body made of high performance concrete, hand-poured
- Each one is unique
- Push mechanism
- With replaceable STAEDTLER jumbo ballpoint refill, blue, M
- Barrel red
- Indelible ink conforming to ISO 12757-2
- Always with STAEDTLER engraving
- Single packaging
- Minimum quantity: 25 pieces



Concrete Stylo-bille

441CON W

- Corps en béton ciré haute qualité, fabriqué à la main
- Chaque pièce est unique
- Bouton-poussoir
- Avec recharge géante STAEDTLER, bleu, M
- Corps rouge
- Encre infalsifiable conforme à la norme ISO 12757-2
- Toujours avec gravure STAEDTLER
- Conditionnement à l'unité
- Quantité minimum : 25 pièces



PROMOTIONAL GIFT
AWARD 2018



⇩ Laser engraving / Gravure au laser

⌈ ⌋ Advertising space / Surface d'impression p. 58



Concrete 2.0 Ballpoint pen

441CON8 W

- Round body made of high performance concrete, hand-poured
- Push mechanism
- Metal tip, clip and pusher
- With replaceable STAEDTLER jumbo ballpoint refill, blue, M
- Indelible ink conforming to ISO 15757-2
- Single packaging
- Minimum quantity: 25 pieces



Concrete 2.0 Stylo-bille

441CON8 W

- Corps rond en béton ciré haute qualité, fabriqué à la main
- Bouton-poussoir
- Pointe, poussoir et clip en métal
- Avec recharge géante STAEDTLER, bleu, M
- Encre infalsifiable conforme à la norme ISO 15757-2
- Conditionnement à l'unité
- Quantité minimum : 25 pièces



⇩ Laser engraving / Gravure au laser

⌈ ⌋ Advertising space / Surface d'impression p. 58





TRX®

- Body made of anodised aluminium
- Triangular shape
- Single packaging



TRX®

- Corps en aluminium anodisé
- Forme triangulaire
- Conditionnement à l'unité



↓ Laser engraving / Gravure au laser
 [] Advertising space / Surface d'impression p. 58



Fountain pen

476TRX W

- Attachable cap
- High-quality stainless steel nib with Mars head
- Writing tip with iridium grain
- Nib widths: M, B
- Equipped with one empty cartridge and one standard STAEDTLER ink cartridge in royal blue
- Minimum quantity: 10 pieces



BLACK / NOIR

BLUE / BLEU

GREEN / VERT

BROWN / BRUN



Stylo-plume

476TRX W

- Capuchon à vis
- Plume en acier poli avec Tête de Mars
- Plume avec pointe en iridium
- Plumes : M et B
- Livré avec une cartouche vide et une cartouche d'encre STAEDTLER (bleu royal)
- Quantité minimum : 10 pièces

Nib widths / Plumes :

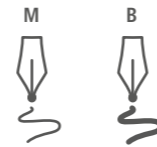

Rollerball pen

412TRX W

- Attachable cap
- With replaceable STAEDTLER rollerball refill, black, M
- Minimum quantity: 10 pieces



BLACK / NOIR

BLUE / BLEU

GREEN / VERT

BROWN / BRUN



Roller

412TRX W

- Capuchon à vis
- Livré avec recharge roller STAEDTLER pointe M (noir)
- Quantité minimum : 10 pièces



Ballpoint pen

440TRX W

- With twist mechanism
- With replaceable STAEDTLER jumbo ballpoint refill, black, B
- Minimum quantity: 10 pieces



Stylo-bille

440TRX W

- Avec mécanisme rotatif
- Avec recharge géante STAEDTLER, noir, B
- Quantité minimum : 10 pièces

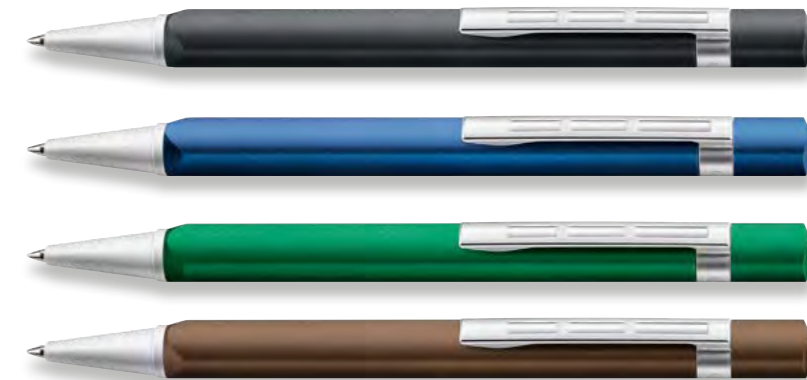

BLACK / NOIR

BLUE / BLEU

GREEN / VERT

BROWN / BRUN



Mechanical pencil

766TRX W

- With twist mechanism
- With STAEDTLER Mars micro mechanical pencil lead 0.7 mm (degree: HB)
- Minimum quantity: 10 pieces



Porte-mine

766TRX W

- Avec mécanisme rotatif
- Livré avec mines graphite Mars micro 0,7 mm (graduation HB)
- Quantité minimum : 10 pièces

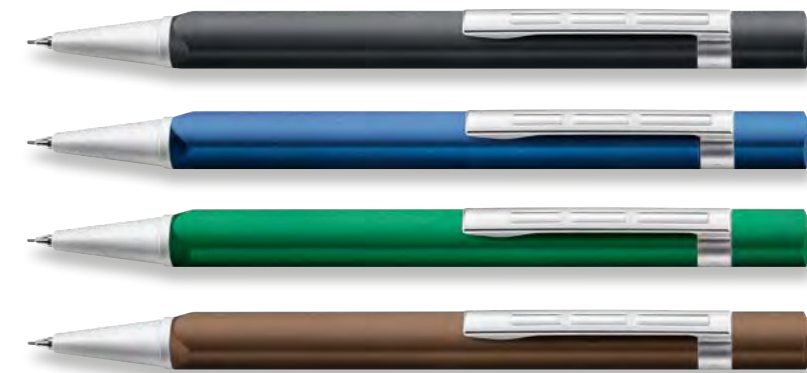

BLACK / NOIR

BLUE / BLEU

GREEN / VERT

BROWN / BRUN



triplus® Fountain pen

474 W

- Fountain pen made of metal
- Ergonomic triangular shape for effortless writing
- Barrel red, anthracite, gold or rose
- Lacquering mat
- Nib widths: F, M
- Equipped with one standard STAEDTLER ink cartridge in royal blue
- Single packaging
- Minimum quantity: 25 pieces



triplus® Stylo-plume

474 W

- Stylo-plume en métal
- Forme triangulaire ergonomique pour une écriture sans effort
- Corps rouge, anthracite, doré ou rosé
- Vernis mat
- Plumes : F, M
- Livré avec une cartouche d'encre STAEDTLER (bleu royal)
- Conditionnement à l'unité
- Quantité minimum : 25 pièces



reddot winner 2021



↓ Laser engraving / Gravure au laser
 [] Engraving area / Zone de gravure p. 58



triplus® Ballpoint pen

444 W

- Retractable ballpoint pen made of metal
- Ergonomic triangular shape for effortless writing
- Barrel red, anthracite, gold or rose
- Lacquering mat
- Indelible ink conforming to ISO 12757-2
- Writing colour blue
- Line width M
- Single packaging
- Minimum quantity: 25 pieces



triplus® Stylo-bille

444 W

- Stylo-bille rétractable en métal
- Forme triangulaire ergonomique pour une écriture sans effort
- Corps rouge, anthracite, doré ou rosé
- Vernis mat
- Encre infalsifiable conforme à la norme ISO 12757-2
- Encre bleue
- Largeur de trait M
- Conditionnement à l'unité
- Quantité minimum : 25 pièces



reddot winner 2021



↓ Laser engraving / Gravure au laser
 [] Engraving area / Zone de gravure p. 59



Retractable ballpoint pen elance 2.0

421 45 W

- Refillable, retractable ballpoint pen made of metal
- Metal jumbo refill
- Indelible ink conforming to ISO 12757-2
- Barrel white glossy, black matt or silver
- Writing colour blue
- Line width M
- Minimum quantity: 250 pieces



Stylo-bille rétractable elance 2.0

421 45 W

- Stylo-bille rétractable et rechargeable en métal
- Recharge métal ultra longue durée
- Encre infalsifiable conforme à la norme ISO 12757-2
- Corps blanc brillant, noir mat ou argent
- Encre bleue
- Largeur de trait M
- Quantité minimum : 250 pièces



↓ Pad printing / Tampographie
 ↓ Laser engraving / Gravure au laser
 [] Advertising space / Surface d'impression p. 59



Mechanical pencil graphite 779

779 W

- Mechanical pencil for writing
- Ergonomic rubberised grip zone
- With metal clip, push-button and tip
- Barrel black or white
- Line width: 0.5 mm (barrel black or white) or 0.7 mm (barrel white)
- Minimum quantity: 250 pieces



Porte-mine graphite 779

779 W

- Porte-mine pour l'écriture
- Zone de préhension ergonomique caoutchoutée
- Pointe, poussoir et clip métal
- Corps noir ou blanc
- Largeur de trait : 0,5 mm (corps noir ou blanc) ou 0,7 mm (corps blanc)
- Quantité minimum : 250 pièces



↓ Pad printing / Tampographie
 [] Advertising space / Surface d'impression p. 59





Noris® writing pen

307 W

- Fineliner with stable, pressure-resistant tip
- DRY SAFE – can be left uncapped for days without drying up
- Washes easily out of most textiles
- Line width F, 4 colours
- Housing made of 97% recycled plastic
- Minimum quantity: 500 pieces



Silk-screen printing / Sérigraphie
 Advertising space / Surface d'impression p. 59

Ink colours /
Couleurs d'encre :



Noris® writing pen

307 W

- Fineliner avec pointe stable et résistante à la pression
- DRY SAFE – permettant de laisser décapuchonné plusieurs jours sans sécher
- Se nettoie facilement sur la plupart des textiles
- Largeur de trait F, 4 couleurs
- Boîtier fabriqué de 97% plastique recyclé
- Quantité minimum : 500 pièces



Pigment liner

308 W

- Fineliner for writing, sketching and drawing
- Pigment ink, indelible, lightfast, waterproof on paper
- CAP OFF – can be left uncapped for at least 12 hours without drying up
- Erasable when used on drafting paper, no bleeding when high-lighted
- Long metal tip, ideal for use with rulers and templates
- 12 line widths, ink colour black
- Minimum quantity: 1,000 pieces

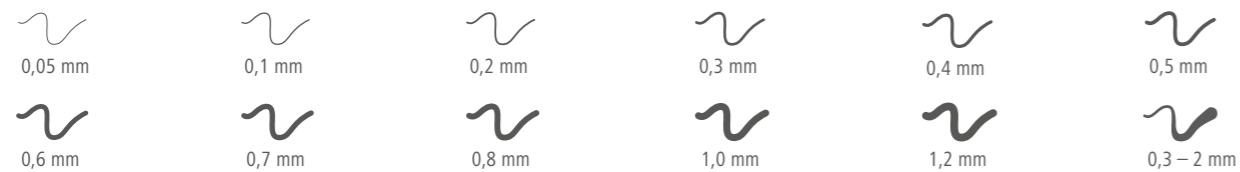

Silk-screen printing / Sérigraphie
 Advertising space / Surface d'impression p. 59



Pigment liner

308 W

- Feutre pour écrire, faire des croquis et dessiner
- Encre pigmentaire, indélébile, résistante à la lumière, étanche à l'eau sur papier
- CAP OFF – peut rester ouvert jusqu'à 12 heures sans sécher
- Effaçable lorsqu'il est utilisé sur du papier à dessin, pas de bavure lorsqu'il est surligné
- Pointe longue en métal, idéale pour une utilisation avec des règles et des gabarits
- 12 largeurs de trait, couleur d'encre noire
- Quantité minimum : 1.000 pièces



Packaging, Gift boxes



Cardboard box

VLR 2

- Black, elegant cardboard box with viewing window
- Suitable for: Mechanical pencils and ballpoint pens (1 or 2 writing instruments) / 6 or 12 graphite pencils / 5 triplus writing instruments



Black cardboard box

V9PTP581FW

- Black cardboard box for elance ballpoint pens and "The Pencil"
- Always with STAEDTLER blind embossing



Conditionnements, Boîtes cadeaux

Étui carton

VLR 2

- Élégant étui carton noir avec fenêtre
- Pour : Porte-mines ou stylos-bille (1 ou 2 instruments d'écriture) / 6 ou 12 crayons graphite / 5 stylos triplus

Étui carton noir

V9PTP581FW

- Étui carton noir pour stylos-bille elance et « The Pencil »
- Avec impression du logo STAEDTLER



Gift box

LR TRPL

- Black cardboard box with bar shaped cutouts
- Always with STAEDTLER logo
- Ideal for triplus ballpoint pens or fountain pens (1 or 2 writing instruments)

Étui cadeau

LR TRPL

- Étui cadeau noir avec découpures
- Avec impression du logo STAEDTLER
- Idéal pour les stylos-bille ou stylos-plume triplus (1 ou 2 instruments d'écriture)

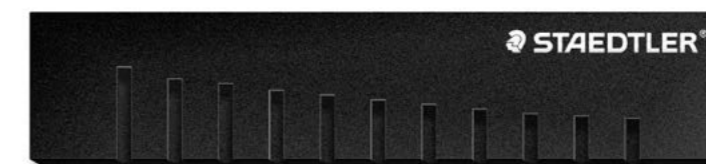



Head of ideas.

Premium gifts Primes



Noris® junior 3 in 1 kids' colouring pencil

140 C6

- Cardboard box containing 6 coloured pencils and 1 sharpener
- 3 in 1: coloured pencil, wax crayon and watercoloured pencil all in one
- For paper, cardboard, glass and much more, including dark surfaces
- Soft strokes in bright colours
- Super thick lead gives extra high break resistance
- Minimum quantity: 50 pieces



Noris® junior crayons de couleur 3 en 1

140 C6

- Étui carton de 6 crayons de couleur et 1 taille-crayon
- 3 en 1: crayon de couleur, crayon de cire et crayon aquarelle
- Pour le papier, le carton, le verre et même des surfaces sombres
- Mine douce aux couleurs intenses
- Grande résistance à la casse grâce à la mine très épaisse
- Quantité minimum : 50 pièces



Noris® junior wax crayon

224 C12

- Cardboard box containing 12 wax crayons and 1 spatula
- Chunky format gives extra high break resistance
- Paper wrapped for clean fingers
- Easy to sharpen
- Minimum quantity: 50 pieces



Noris® junior craies de cire

224 C12

- Étui carton de 12 crayons de cire et 1 racloir
- Grande résistance à la casse grâce au format compact
- Recouverts de papier pour des doigts propres
- Faciles à tailler
- Quantité minimum : 50 pièces



Noris® junior finger paints

8814 D

- Cardboard box containing 4 finger paints
- Can be applied to paper, cardboard, wood and glass/ windows using fingers, a sponge, spatula or paint brush
- Easy to blend
- Fast-drying
- Minimum quantity: 50 pieces



Noris® junior peintures au doigt

8814 D

- Étui carton de 4 peintures au doigt
- Application au doigt, à l'éponge, à la spatule ou au pinceau sur le papier, le carton, le bois et le verre/les fenêtres
- Facile à mélanger
- Séchage rapide
- Quantité minimum : 50 pièces



Children 2+

Enfants 2+



**Noris® junior drawing set for toddlers**

61 C1

Mixed set with drawing activities for toddlers

Cardboard carry box containing:

- 6 Noris junior wax crayons
- 1 Noris junior kids' graphite pencil
- 1 drawing activities booklet
- Minimum quantity: 100 sets

**Set de dessin Noris® junior pour les tout-petits**

61 C1

Kit mixte de dessin pour les tout-petits

Boîte de transport en carton contenant :

- 6 Noris junior craies de cire
- 1 Noris junior crayon à papier
- 1 livre de coloriage
- Quantité minimum : 100 sets

**Noris® junior crafting set for toddlers**

61 C2

Mixed set with fingerpainting and crafting activities for toddlers

Cardboard carry box containing:

- 4 Noris junior fingerpainting tubes 75 ml
- 1 Noris junior safety scissors
- 1 drawing activities booklet
- Minimum quantity: 100 sets

**Set créatifs Noris® junior pour les tout-petits**

61 C2

Set créatif de peinture aux doigts Noris® junior pour les tout-petits

Boîte de transport en carton contenant :

- 4 tubes Noris junior de peinture aux doigts 75 ml
- 1 Noris junior paire de ciseaux
- 1 livret de dessin
- Quantité minimum : 100 sets

**Noris® jumbo sticker crafting set for preschool children**

61 C4

Mixed set with paper figures crafting templates for preschool children

Cardboard carry box containing:

- 12 Noris jumbo wax crayons
- 1 Noris glue stick
- 1 Noris hobby scissors
- 4 crafting templates
- Minimum quantity: 100 sets

**Set créatif d'autocollants Noris® jumbo pour enfants d'âge préscolaire**

61 C4

Set créatif avec figurines en papier pour enfants d'âge préscolaire

Boîte de transport en carton contenant :

- 12 craies à la cire Noris jumbo
- 1 bâton de colle Noris
- 1 paire de ciseaux Noris
- 4 feuilles de bricolage
- Quantité minimum : 100 sets

**Noris® colour coloured pencil "People of the World"**

185 C12POW

- Cardboard box with 12 coloured pencils made from Upcycled Wood
- Ergonomic soft surface
- High break-resistance
- Minimum quantity: 100 pieces

**Noris® colour crayons de couleur « People of the World »**

185 C12POW

- Étui carton de 12 crayons de couleur made from Upcycled Wood
- Surface douce ergonomique
- Haute résistance au bris
- Quantité minimum : 100 pièces

**Noris® paint box**

888 NC12

- Paint set with 12 interchangeable paint pots
- 1 tube of opaque white and brush
- Cover with palette for mixing
- Brilliant colours with high covering capacity
- All colours can be mixed with one another
- Minimum quantity: 120 pieces

**Boite de peinture Noris®**

888 NC12

- Set de peinture avec 12 pastilles interchangeables
- 1 tube de blanc opaque avec pinceau
- Couvercle avec palette pour le mélange des couleurs
- Couleurs intenses à fort pouvoir couvrant
- Couleurs miscibles entre elles
- Quantité minimum : 120 pièces

**Noris® crafting scissors**

965 14 / 965 14L

- Scissors with 14 cm blade
- For right- or left-handers
- High quality cutting
- Stainless steel, rounded blades
- Soft, ergonomic grip zone
- Long service life
- Minimum quantity: 120 pieces

**Noris® ciseaux pour loisirs créatifs**

965 14 / 965 14L

- Ciseaux avec lames 14 cm
- Pour droitiers ou gauchers
- Coupe de haute qualité
- Lames arrondies en inox
- Zone de prise en main souple et ergonomique
- Longue durée de vie
- Quantité minimum : 120 pièces





p. 05 Graphite pencils made from home grown lime wood Crayon graphite en bois de tilleul local

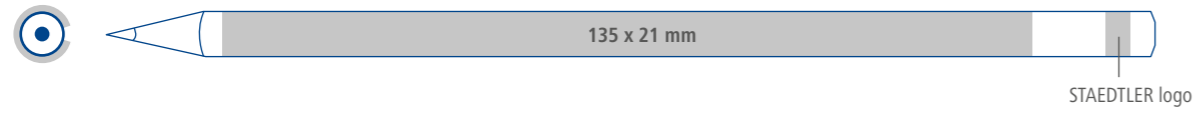

p. 06 Graphite pencils – round Crayons graphite – ronds

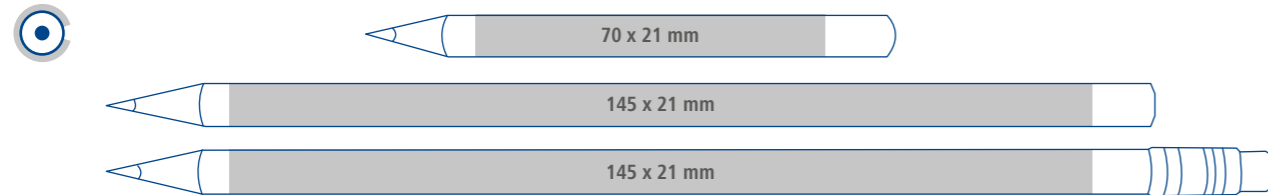

p. 07 Graphite pencils – hexagonal Crayons graphite – hexagonaux

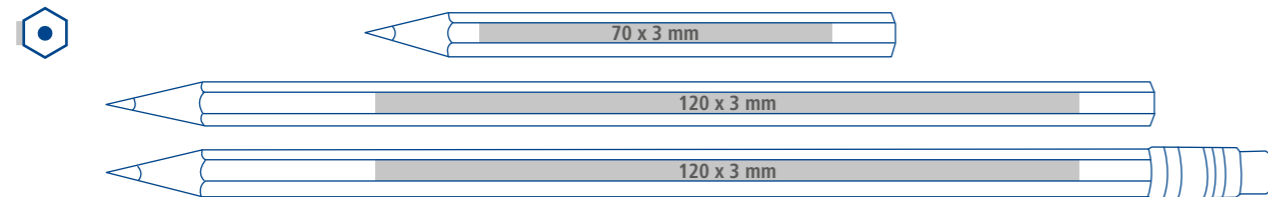

p. 08 Graphite pencils in triangular shape Crayons graphite triangulaires

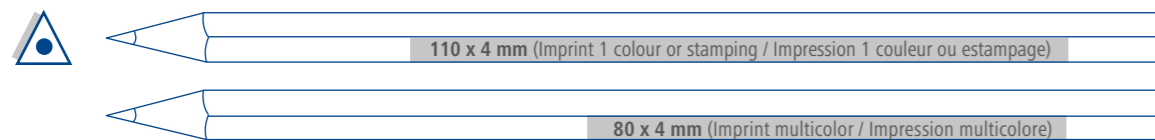

p. 08 Graphite pencils in triangular shape jumbo Crayons graphite triangulaires jumbo

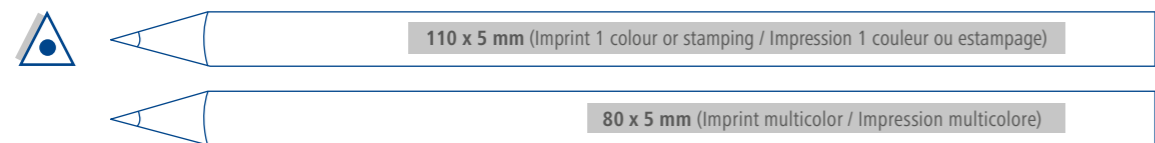

p. 09 Black-dyed graphite pencils Crayons graphite teintés dans la masse



p. 09 Design graphite pencil Crayon graphite design



p. 10 Carpenter pencils Crayons charpentier

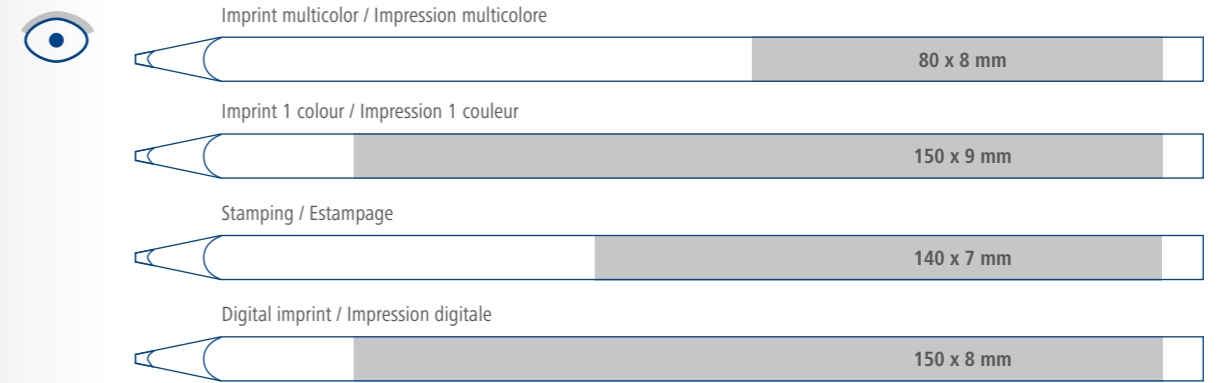

p. 10, 11 The Pencil The Pencil

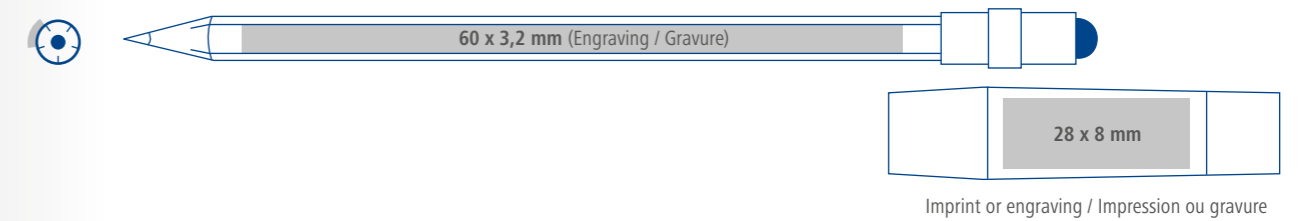

p. 11 Noris® digital mini Noris® digital mini



p. 12 Erasers Gommages

Digital imprint: entire area with border distance 2 mm

Impression digitale: sur toute la surface avec bord distance 2 mm

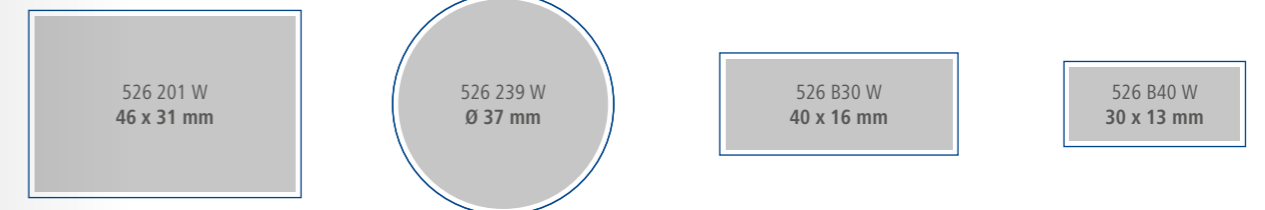

p. 15 Coloured pencils Crayons de couleur

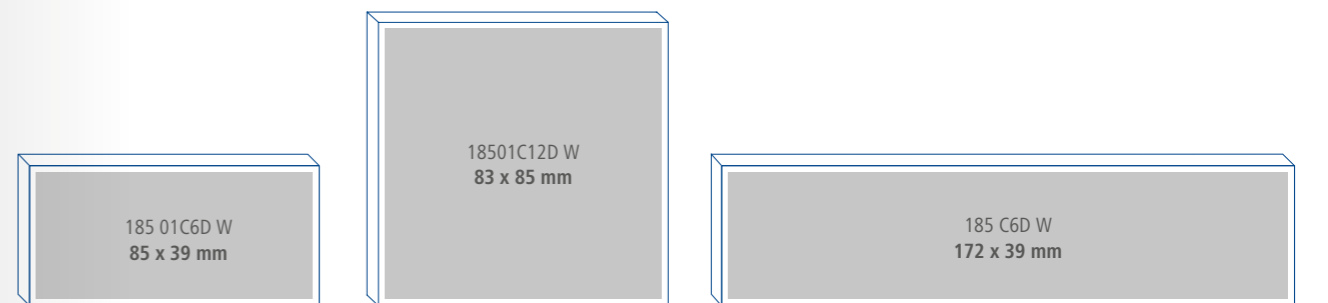

p. 16 Rainbow pencil Crayon « arc en ciel »



p. 18 triplus® color triplus® color

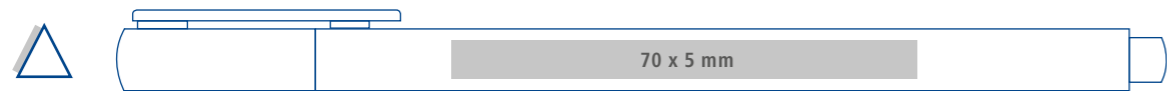

p. 19 Sidewalk chalks / Craies pour trottoir Modelling clay / Pâte à modeler

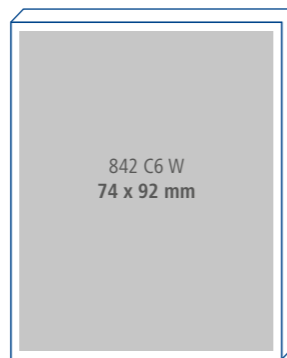
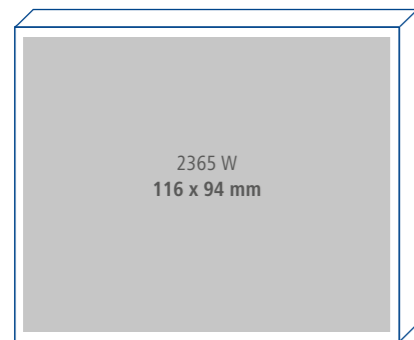

p. 20-21 STAEDTLER® creative set / Set creatif STAEDTLER® FIMO® kids "form&play"

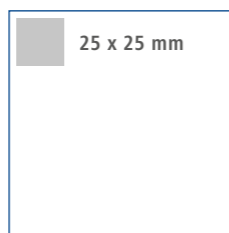
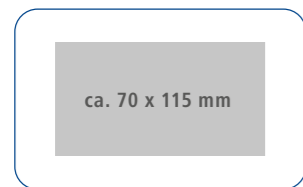

p. 23-24 Textsurfer® Textsurfer®

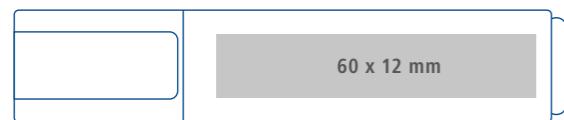

p. 25 Textsurfer® classic desk stand Set de bureau Textsurfer®

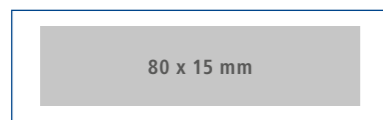

p. 25 Textsurfer® dry Textsurfer® dry

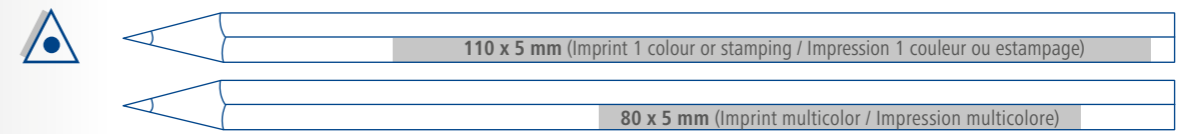

p. 28-30, 34 Lumocolor® permanent special / permanent / non-permanent / whiteboard pen Lumocolor® permanent special / permanent / non-permanent / whiteboard pen

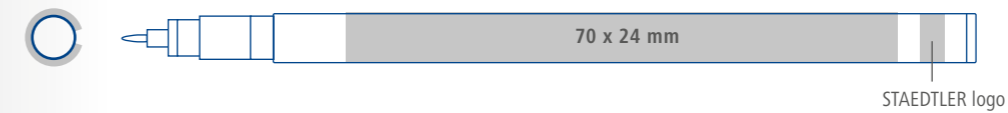

Imprint 1 colour / Impression 1 couleur
(More colours: depending on motive / Plusieurs couleurs : selon le motif)

p. 31, 32, 33 Lumocolor® permanent marker / flipchart marker / whiteboard marker Lumocolor® permanent marker / flipchart marker / whiteboard marker

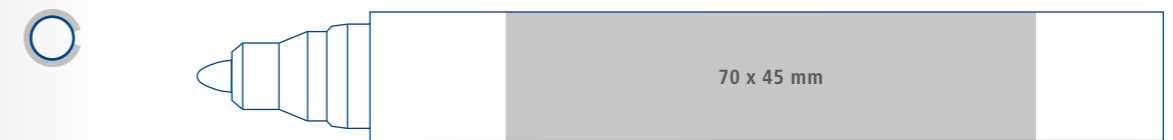

Imprint 1 colour / Impression 1 couleur
(More colours: depending on motive / Plusieurs couleurs : selon le motif)

p. 32 Lumocolor® permanent duo Lumocolor® permanent duo



p. 35 Lumocolor® correctable Lumocolor® correctable



Imprint 1 colour / Impression 1 couleur
(More colours: depending on motive / Plusieurs couleurs : selon le motif)

p. 39-41 triplus® fineliner / ball / roller / textsurfer® triplus® fineliner / ball / roller / textsurfer®



p. 40 triplus® micro triplus® micro

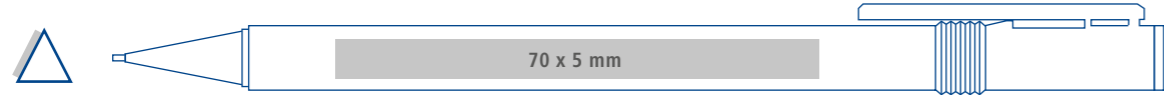

p. 43 Concrete Ballpoint pen Concrete Stylo-bille

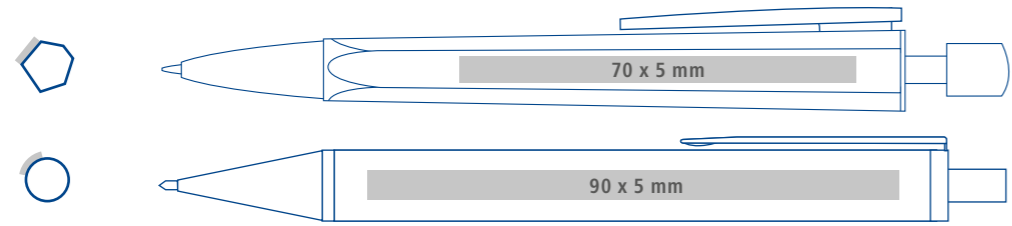

p. 44 TRX® Fountain pen / Rollerball pen TRX® Stylo-plume / Roller

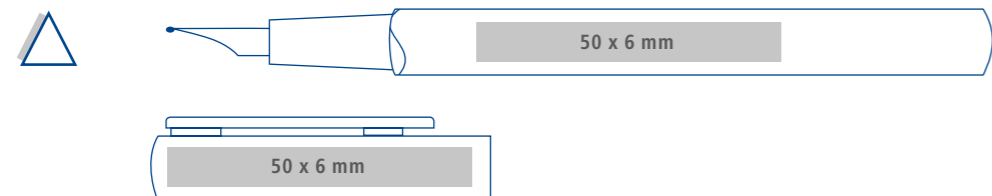

p. 45 TRX® Ballpoint pen / Mechanical pencil TRX® Stylo-bille / Porte-mine



p. 46 triplus® Fountain pen triplus® Stylo-plume

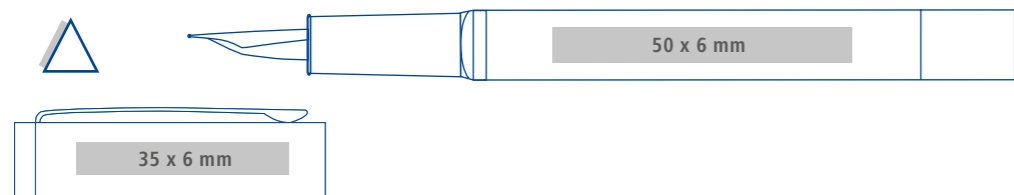

p. 46 triplus® Ballpoint pen triplus® Stylo-bille



p. 47 Retractable ballpoint pen elance 2.0 Stylo-bille rétractable elance 2.0



STAEDTLER Box

Label / Étiquette :

| | | | |
|-----------------------------------|--------------------|---------------------------|--------------------|
| Lumocolor p. 29, 30, 34, 35 | 31 WP4: 68 x 34 mm | tripus p. 18, 38-41 | SB4 W: 70 x 29 mm |
| Lumocolor p. 31, 33 | 35 WP4: 68 x 53 mm | tripus p. 18 | SB6 W: 70 x 50 mm |
| | | tripus p. 18 | SB10 W: 70 x 90 mm |
| | | ergosoft p. 16 | SB12 W: 70 x 90 mm |

p. 47 Mechanical pencil graphite 779 Porte-mine graphite 779

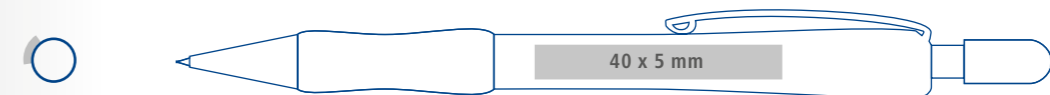

p. 48 Noris® writing pen Noris® writing pen

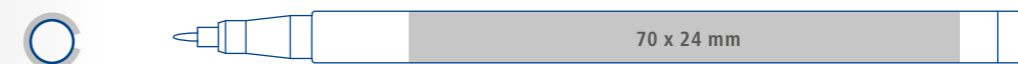

Imprint 1 colour / Impression 1 couleur
(More colours: depending on motive / Plusieurs couleurs : selon le motif)

p. 48 Pigment liner Pigment liner



PROMOTIONAL PRODUCTS

 © STAETTLER SE
Moosackerstraße 3
90427 Nürnberg

 www.staedtler-promotional.com
 promotional.products@staedtler.com

Subject to modifications.
Sous réserve de modifications.

0K804Z6003